

N-TRON

THE INDUSTRIAL NETWORK COMPANY



The strongest link in your network

Unmanaged Ethernet



Process Control



Media Converter



Managed Ethernet



Gigabit Ethernet



Wireless Access



Industrial PoE



RUGGED • RELIABLE • AFFORDABLE

ETHERNET FOR INDUSTRIAL APPLICATIONS



Plants depend on ***N-TRON*** Non-Stop

N-TRON Corp. is located in Mobile, Alabama. **N-TRON** products are available from **N-TRON's** worldwide network of distributors, and our products are made in the U.S.A..

For a distributor near you, contact us at +1 (251) 342-2164 or visit us on the web at www.n-tron.com.

Non-warranty related returns must be made within 30 days from the original date of shipment and are subject to a re-stocking fee. Singlemode fiber products and custom length cables are non-returnable; non-refundable. All returns require prior authorization. Shipping costs are not included.

N-TRON Manufactures High Performance Hardened Switches

N-TRON® manufactures a family of hardened industrial Ethernet Switches designed specifically for industrial, marine, utility, and military users requiring high reliability, superior performance, and exceptional noise immunity.

N-TRON Switches use store-and-forward architecture and are designed to operate in applications needing extended temperatures (ranging from -40°C to 85°C), high shock and vibration specifications, elevated RFI/EMI environments, and are UL Listed for use in Class I, Division 2 Hazardous areas. Our products feature wide ranging redundant power supply inputs, and can be DIN-Rail, panel, or rack mounted. N-TRON offers IEEE 802.3 10/100BaseTX twisted pair copper and 100BaseFX fiber optic ports, and Gigabit capability on our 1000, 7000, and 9000 series. Our multimode fiber models are capable of driving up to 2km of multimode fiber optic cable. Singlemode fiber models are able to extend distances ranging from 15km to 80km of singlemode fiber optic cable.

N-TRON's N-View™ OPC Server Software is available for use with the N-TRON 200, 300, 400, 500, and 900 Series Switches with the N-View firmware option; and is provided as a standard feature on all 700, 7000, and 9000 Series Switches. N-View OPC Software provides switch and port status information of N-View capable switches, for use in popular OPC client HMI Software Packages. N-View is currently available for Windows NT 4.0 w/SP4 or later, Windows 2003 Server, Windows 2000, XP, Vista, and Windows 7 operating systems.

Industrial Features and Specifications*

- Rugged Metal Enclosures for High Noise Environments
- DIN-Rail Mount, Panel Mount, & Rackmount Available
- Store-and-forward Wire Speed Technology
- Redundant Power Inputs
- Low Current Requirements
- All TX Ports Support Unshielded Twisted Pair (UTP) or Shielded Twisted Pair (STP) Cabling
- Wide Range of Fiber Optic Transceivers 2km, 15km, 40km, or 80km
- ESD Overvoltage Protection Diodes on all I/O Ports
- 1 to 2 Million Hours Mean Time Between Failure
- Shock: 200g for 10ms
- Seismic Triaxial: 50g, 5-200Hz, 15 sec.
- Extended Operating Temperatures
- IP67 Rated Models available
- FCC Part 15 Class A
- CE: EN61000-6-2,4, EN55011, EN61000-4-2,3,4,5,6
- UL 1604 C Listed (US, Canada) Class I, Div. 2 Hazardous Location
- ATEX Zone 2, Category 3G, Ex nC Mark
- IEEE 1613 Compliance (Electric Utility Substation)
- NEMA TS1/TS2 Compliance (Traffic Control)
- American Bureau of Shipping (ABS) Type Approval
- EN50155 for Railway Applications
- RoHS Compliance
- GOST-R Certified

*Refer to product details for applicable specifications

Unmanaged and PoE

100 Series



4-9

1000 Series Gigabit



9

Monitored

300 Series -N Option



10-13

900 Series -N Option



14-15

Process Control

500 Series -A Option



16-18

Fully Managed

700 Series including Wireless



22-27

7000 Series Gigabit Capable



27, 28-31

9000 Series Gigabit Capable



32-33

Options and Accessories

Advanced Features	19
N-View Software	20-21
EtherNet/IP™ with CIP Msg.	30
Serial Devices	34-35
N-Ring Fault Mapping	36
Network Topologies	37-41
Peripherals	42-43

Affordable Entry-Level Industrial Fast Ethernet Products

The *N-TRON* 100 Series, provides economical, entry-level fast Ethernet switches and peripheral products designed to expand your Industrial Ethernet network. This flexible line is ideal for data acquisition, control, and Ethernet I/O applications requiring unmanaged, affordable products. Our 104TX, 105TX, and 108TX copper switches offer compact, unmanaged Ethernet switches ideal for increasing network bandwidth and determinism. Multimode and Singlemode Fiber models are also available with *N-TRON*'s 102MC Media Converter, 105FX, five port switch, and 106FX2, six port switch. Standard voltage 100 Series models are UL Listed for use in Class I, Division 2 hazardous locations. High voltage models are TÜV/GS certified. Select models are also ABS approved for maritime environments, and EN50155 certified for railway applications.



ABB Industrial IT™ Certified

104TX

- Four RJ-45 10/100BaseTX Copper Ports
- Compact Size provides a Small Footprint
- Unmanaged Operation
- Full Wire Speed Communications
- Supports Full/Half Duplex Operation
- Case Dimensions (2.9" h x 1.5" w x 3.6" d, 0.6 lbs.)
- -40°C to 80°C Operating Temperature
- Hardened Metal DIN-Rail Enclosure
- Redundant Power Inputs 10-30 VDC, 215 mA @ 24V
- Hardened ESD Protection Diodes on all Ports
- Surge Protection Diodes on Power Inputs
- Order Part #104TX

105TX

- Five RJ-45 10/100BaseTX Copper Ports
- Compact Size provides a Small Footprint
- Unmanaged Operation
- Full Wire Speed Communications
- Supports Full/Half Duplex Operation
- Case Dimensions (2.9" h x 1.5" w x 3.6" d, 0.6 lbs.)
- -40°C to 80°C Operating Temperature
- Hardened Metal DIN-Rail Enclosure
- Redundant Power Inputs 10-30 VDC, 215 mA @ 24V
- Hardened ESD Protection Diodes on all Ports
- Surge Protection Diodes on Power Inputs
- Order Part #105TX

108TX

- Eight RJ-45 10/100BaseTX Copper Ports
- Compact Size provides a Small Footprint
- Unmanaged Operation
- Full Wire Speed Communications
- Supports Full/Half Duplex Operation
- Case Dimensions (3.5" h x 1.5" w x 3.6" d, 0.7 lbs.)
- -40°C to 70°C Operating Temperature
- Hardened Metal DIN-Rail Enclosure
- Redundant Power Inputs 10-30 or 10-60 VDC, 250 mA @24V
- Hardened ESD Protection Diodes on all Ports
- Surge Protection Diodes on Power Inputs
- Order Part #108TX
- Order Part #108TX-HV



102MC

- One RJ-45 10/100BaseTX Copper Port
- One 100BaseFX Full Duplex Fiber Port
- Unmanaged Media Converter
- Full Wire Speed Communications
- RJ-45 Port Supports Full/Half Duplex Operation
- Case Dimensions (2.9" h x 1.5" w x 3.6" d, 0.5 lbs.)
- -40°C to 80°C Operating Temperature
- Hardened Metal DIN-Rail Enclosure
- Redundant Power Inputs 10-30 VDC, 140 mA @ 24V
- Hardened ESD Protection Diodes on RJ-45 Port
- Surge Protection Diodes on Power Inputs
- Order MM Part #102MC-XX
Order SM Part #102MCE-XX-YY

105FX

- Four RJ-45 10/100BaseTX Copper Ports
- One 100BaseFX Full Duplex Fiber Port
- Unmanaged Operation
- Full Wire Speed Communications
- RJ-45 Port Supports Full/Half Duplex Operation
- Case Dimensions (3.5" h x 1.5" w x 3.6" d, 0.6 lbs.)
- -40°C to 70°C Operating Temperature
- Hardened Metal DIN-Rail Enclosure
- Redundant Power Inputs 10-30 VDC, 270 mA @ 24V
- Hardened ESD Protection Diodes on RJ-45 Port
- Surge Protection Diodes on Power Inputs
- Order MM Part #105FX-XX
Order SM Part #105FXE-XX-YY

106FX2

- Four RJ-45 10/100BaseTX Copper Ports
- Two 100BaseFX Full Duplex Fiber Ports
- Unmanaged Operation
- Full Wire Speed Communications
- RJ-45 Ports Support Full/Half Duplex Operation
- Case Dimensions (3.5" h x 1.5" w x 3.6" d, 0.6 lbs.)
- -40°C to 70°C Operating Temperature
- Hardened Metal DIN-Rail Enclosure
- Redundant Power Inputs 10-30 VDC, 270 mA @ 24V
- Hardened ESD Protection Diodes on RJ-45 Ports
- Surge Protection Diodes on Power Inputs
- Order MM Part #106FX2-XX
Order SM Part #106FXE2-XX-YY

Ordering Key: MM = multimode fiber, SM = singlemode fiber, "XX" = SI or SC for fiber style connector, "E" = singlemode fiber, "YY" = 15, 40, or 80 for 15km, 40km, or 80km SM fiber length. "HV" = High Voltage Model



110FX2

- Eight RJ-45 10/100BaseTX Copper Ports
- Two 100BaseFX Full Duplex Fiber Ports
- Unmanaged Operation
- Full Wire Speed Communications
- RJ-45 Ports Supports Full/Half Duplex Operation
- Case Dimensions (4.3" h x 2.4" w x 4.6" d, 1.5 lbs.)
- -40°C to 80°C Operating Temperature
- Hardened Metal DIN-Rail Enclosure
- Redundant Power Inputs 10-49 VDC, 355 mA @ 24V
- Hardened ESD Protection Diodes on all RJ-45 Ports
- Surge Protection Diodes on Power Inputs
- Order MM Part #110FX2-XX
Order SM Part #110FXE2-XX-YY

111FX3

- Eight RJ-45 10/100BaseTX Copper Ports
- Three 100BaseFX Full Duplex Fiber Ports
- Unmanaged Operation
- Full Wire Speed Communications
- RJ-45 Ports Supports Full/Half Duplex Operation
- Case Dimensions (4.3" h x 2.4" w x 4.6" d, 1.5 lbs.)
- -40°C to 80°C Operating Temperature
- Hardened Metal DIN-Rail Enclosure
- Redundant Power Inputs 10-49 VDC, 410 mA @ 24V
- Hardened ESD Protection Diodes on all RJ-45 Ports
- Surge Protection Diodes on Power Inputs
- Order MM Part #111FX3-XX
Order SM Part #111FXE3-XX-YY

112FX4

- Eight RJ-45 10/100BaseTX Copper Ports
- Four 100BaseFX Full Duplex Fiber Ports
- Unmanaged Operation
- Full Wire Speed Communications
- RJ-45 Ports Supports Full/Half Duplex Operation
- Case Dimensions (4.3" h x 3.1" w x 4.6" d, 1.9 lbs.)
- -40°C to 80°C Operating Temperature
- Hardened Metal DIN-Rail Enclosure
- Redundant Power Inputs 10-49 VDC, 455 mA @ 24V
- Hardened ESD Protection Diodes on all RJ-45 Ports
- Surge Protection Diodes on Power Inputs
- Order MM Part #112FX4-XX
Order SM Part #112FXE4-XX-YY

N-TRON's Newest Products

Unmanaged Ethernet with Eight Copper and up to Six Fiber Ports



114FX6

- Eight RJ-45 10/100BaseTX Copper Ports
- Six 100BaseFX Full Duplex Fiber Ports
- Unmanaged Operation
- Full Wire Speed Communications
- RJ-45 Ports Supports Full/Half Duplex Operation
- Case Dimensions (4.3" h x 3.1" w x 4.6" d, 1.10 lbs.)
- -40°C to 80°C Operating Temperature
- Hardened Metal DIN-Rail Enclosure
- Redundant Power Inputs 10-49 VDC, 545 mA @ 24V
- Hardened ESD Protection Diodes on all RJ-45 Ports
- Surge Protection Diodes on Power Inputs
- Order MM Part #114FX6-XX
Order SM Part #114FXE6-XX-YY



N-TRON's compact 100 series, the 110FX2, 111FX3, 112FX4, and 114FX6, are tough network devices designed for full-wire speed communications in industrial data acquisition, control, and Ethernet I/O applications. The series offers a combination of eight copper ports and up to six fiber ports.

Fiber optic communication provides excellent noise immunity for environments where high electromagnetic interference (EMI) is a factor—an ever present consideration in railway, wind farm, and utility installations. The fiber connection supports extended distances, up to 80 km. The switches' ultra compact size and versatile mounting options allow these affordable devices to be used anywhere on the network, even in areas where space is very limited.

Rugged Unmanaged Fast Ethernet Switches IP67 Rated for Harsh Environments

Ideal for mission critical data acquisition, control, and Ethernet I/O applications with severe environmental conditions, N-TRON's 105M12 and 108M12 unmanaged fast Ethernet Switches are IP67 rated for protection against dust, low and high pressure water jets, and temporary immersion in water. These units utilize standard M12 D-Coded connectors for either five or eight 10/100BaseTX copper ports and carry extended operating temperatures, high MTBF, and other specifications for unbeatable reliability. Standard voltage models are UL Listed for use in Class I, Division 2 hazardous locations; ABS and DNV approved for maritime environments. High voltage models are TÜV/GS certified. All models are EN50155 certified for railway applications.



105M12

- Five 10/100BaseTX Copper Ports with M12 D-Coded Female 4 Pin Connectors
- Unmanaged Operation
- IP67 Rated Hardened Metal Enclosure Bulkhead Mountable (DIN-Rail Mounting Option Available)
- Protected Against Low/High Pressure Water Jets and Temporary Immersion in Water
- Totally Protected Against Dust Ingress
- Case Dimensions (5.0" h x 4.4" w x 1.8" d, 1.8 lbs.)
- -40°C to 80°C Operating Temperature
- Supports up to 2,000 MAC Addresses
- Full/Half Duplex Operation Auto Sensing Speed and Flow Control
- ESD Protection Diodes on all Ports Surge Protection Diodes on Power Inputs
- Redundant Power Inputs 10-30 VDC, 215mA @ 24V
- Order Part #105M12

108M12

- Eight 10/100BaseTX Copper Ports with M12 D-Coded Female 4 Pin Connectors
- Unmanaged Operation
- IP67 Rated Hardened Metal Enclosure Bulkhead Mountable (DIN-Rail Mounting Option Available)
- Protected Against Low/High Pressure Water Jets and Temporary Immersion in Water
- Totally Protected Against Dust Ingress
- Case Dimensions (6.7" h x 6.7" w x 1.8" d, 3.3 lbs.)
- -40°C to 70°C Operating Temperature
- Supports up to 2,000 MAC Addresses
- Full/Half Duplex Operation Auto Sensing Speed and Flow Control
- ESD Protection Diodes on all Ports Surge Protection Diodes on Power Inputs
- Redundant Power Inputs 10-30 or 10-60 VDC, 250mA @ 24V
- Order Part #108M12
- Order Part #108M12-HV for High Voltage Model

Power over Ethernet and Gigabit Products with -40°C to 85°C Operating Temperature

N-TRON's Industrial Power over Ethernet (*iPoE*) is designed to transmit power, along with data, over an Ethernet network and is ideal for PoE capable devices where running an AC power feed is either not possible or cost effective. This feature allows an end-user to power a PoE camera, wireless access point, or any other PoE capable device without the need for running separate wires for power. N-TRON's PoE Series products are UL listed for use in Class I, Division 2 Hazardous locations, ABS approved for maritime environments, and EN50155 certified for railway applications.

Built for toughness and speed, the 1000 Series is ideal for industrial data acquisition, control and Ethernet I/O applications where a smaller footprint and gigabit speed is preferred. For ease of ordering, the 1003GX2 comes pre-configured with multimode or singlemode fiber SFP transceivers. The pre-configured ordering information is: 1003GX2-SX for two matching multimode full duplex fiber SFPs, or 1003GX2-LX-ZZ for two matching singlemode full duplex fiber SFPs (See ordering key below). The 1003GX2 may also be ordered a la carte allowing you to mix-and-match various lengths of multimode and singlemode full duplex fiber. The 1000 Series is UL listed for use in Class I, Division 2 Hazardous locations, and ABS approved for maritime environments.



Industrial PoE

- Designed to Transmit Power along with Data over an Ethernet Network
- Ideal for PoE Cameras, Wireless Access Points, or other PoE Devices
- PoE Splitter Allows Devices which are not PoE Capable to be Connected and Powered by Cat5 Cable
- Auto-Detection of Connected PoE Capable Devices
- Full IEEE 802.3af Compliance
- PoE Case Dimensions (3.5" h x 1.5" w x 3.6" d, 0.7 lbs.)
- 100-POE-SPL Case Dimensions (4.0" h x 1.0" w x 3.7" d, 0.6 lbs.)
- -40°C to 85°C Operating Temperature
- Supports 15.4 Watts per Port (13 Watts at the PD) Redundant Power Inputs 46-49 VDC (46-54 on 100-POE-SPL)
- Two Port Ethernet *iPoE* Splitter
Order Part #100-POE-SPL-CC
- Four *iPoE* MidSpan Power Injector
Order Part #100-POE4
- Four *iPoE* Switch Ports plus 10/100BaseTX Uplink
Order Part #105TX-POE
- Four *iPoE* Switch Ports plus 100BaseFX Full Duplex Fiber Uplink
Order MM Part #105FX-XX-POE, SM Part #105FXE-XX-YY-POE

1000 Series Gigabit

- Compact Industrial Ethernet Gigabit Switches, Ideal for Smaller Spaces
- Plug-and-play Unmanaged Operation
- RJ-45 Ports Support Full/Half Duplex Operation
- Auto Sensing Speed and Flow Control (RJ-45)
- Full IEEE 802.3, 802.3u, 802.3z and 802.3ab Compliance
- Case Dimensions (4.0" h x 1.0" w x 3.7" d, 0.6 lbs.)
- -40°C to 85°C Operating Temperature
- Fully Redundant Power Inputs (10-30 VDC)
- ESD Protection Diodes on RJ-45 Ports and Surge Protection Diodes on Power Inputs
- Five 10/100/1000BaseT Ports
Order Part #1005TX
- One 10/100/1000BaseT Port & One 1000BaseSX/LX SFP Port
Order MM Part #1002MC-SX, SM Part #1002MC-LX-ZZ
- Mix-and-Match Multimode & Singlemode SFP Transceivers
Order Part #1003GX2-B plus NTSFP-SX or NTSFP-LX-ZZ

Ordering Key: MM = multimode fiber, SM = singlemode fiber, "CC" = 12, 24, or 48VDC output, "XX" = ST or SC for fiber style connector, "E" = singlemode fiber, "YY" = 15, 40, or 80 for 15km, 40km, or 80km SM fiber length of PoE Devices, "ZZ" = 10, 40, or 80 for SM fiber length of Gigabit Products.

Unmanaged Fast Ethernet Switches with Remote Monitoring (-N)

The *N-TRON* 300 Series of hardened industrial Ethernet switches offer high reliability and full wire speed communications, in a compact size, ideal for use in mission critical, industrial, data acquisition, control, and Ethernet I/O applications. These DIN-Rail mounted switches are designed to exceed the most demanding industrial communications needs and environmental conditions, while providing high throughput and minimum downtime. The 300 Series switches configured with the N-View option, can be monitored using standard OPC compliant HMI software in order to provide complete network monitoring and performance alarms. Handling up to 4,000 MAC addresses, these products support extremely sophisticated and complex network architectures. The 300 Series provides an affordable solution, while maintaining the simplicity of a plug-and-play auto sensing switch. Select 300 Series switches are supplied with the following regulatory approvals: FCC Part 15 Class A, UL 1604 C Listed (U.S. & Canada) for Class I, Div. 2 Hazardous Locations, IEEE 1613 Compliance (Electric Utility Substation), ABS Type Approval (Maritime), and NEMA TS1/TS2 Compliance (Traffic Control).



304TX-N

- Four RJ-45 10/100BaseTX Ports
- Supports UTP or STP Cabling
- Compact Size, Small Footprint (3.1" h x 2.1" w x 3.4" d, 0.8 lbs.)
- -20°C to 70°C Operating Temperature
- Rugged Industrial DIN-Rail Enclosure
- Full Wire Speed Communications
- Redundant Power Inputs 10-30 VDC, 250 mA @ 24V
- Auto Negotiates Speed, Duplex, and MDIX
- UL Listed Class I, Div. 2 for Hazardous Locations
- N-View OPC Monitoring Included with -N model
- Hardened ESD Port Protection
- Order Part #304TX-N

306TX-N

- Six RJ-45 10/100BaseTX Ports
- Supports UTP or STP Cabling
- Compact Size, Small Footprint (3.1" h x 2.1" w x 3.4" d, 0.8 lbs.)
- -20°C to 70°C Operating Temperature
- Rugged Industrial DIN-Rail Enclosure
- Full Wire Speed Communications
- Redundant Power Inputs 10-30 VDC, 250 mA @ 24V
- Auto Negotiates Speed, Duplex, and MDIX
- UL Listed Class I, Div. 2 for Hazardous Locations
- N-View OPC Monitoring Included with -N model
- Hardened ESD Port Protection
- Order Part #306TX-N

308TX-N

- Eight RJ-45 10/100BaseTX Ports
- Supports UTP or STP Cabling
- Compact Size, Small Footprint (3.5" h x 2.1" w x 3.4" d, 0.8 lbs.)
- -20°C to 70°C Operating Temperature
- Rugged Industrial DIN-Rail Enclosure
- Full Wire Speed Communications
- Redundant Power Inputs 10-30 VDC, 250 mA @ 24V
- Auto Negotiates Speed, Duplex, and MDIX
- UL Listed Class I, Div. 2 for Hazardous Locations
- N-View OPC Monitoring Included with -N model
- Hardened ESD Port Protection
- Order Part #308TX-N

Ordering Key: "-N" = N-View OPC Switch Monitoring, leave blank for no monitoring option.

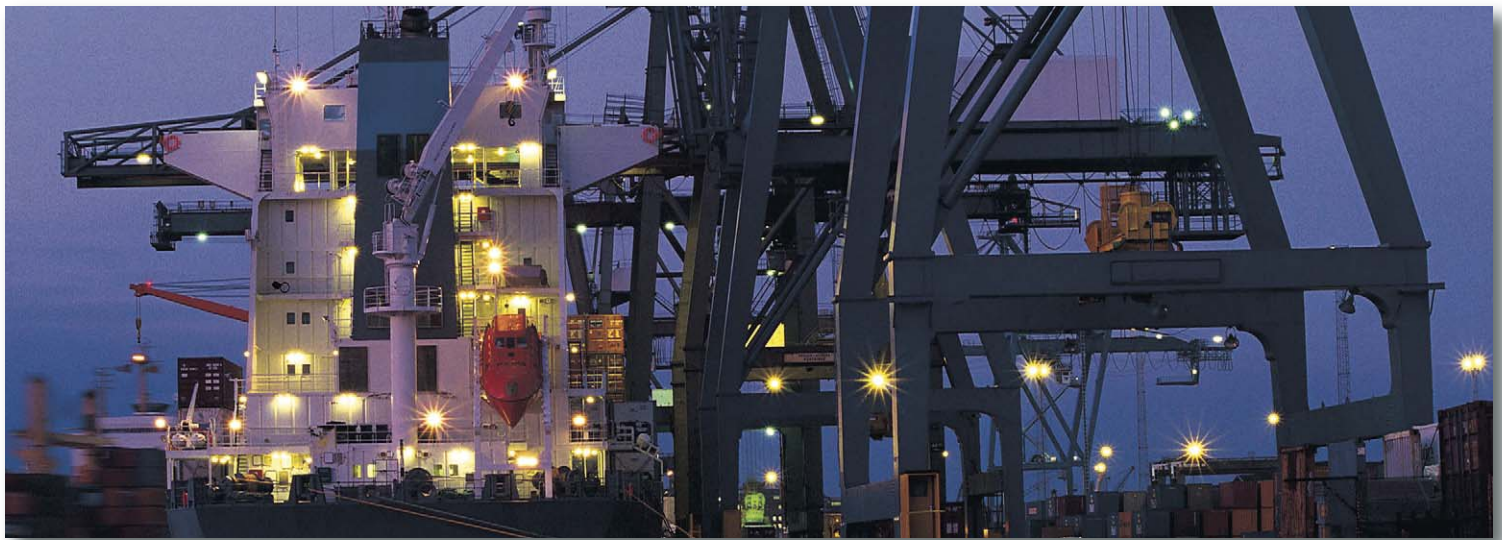

302MC-N

- One RJ-45 10/100BaseTX Port
- One 100BaseFX ST or SC Full Duplex Port
- Compact Size, Small Footprint (3.0" h x 2.1" w x 3.2" d, 0.8 lbs.)
- -20°C to 70°C Operating Temperature
- Rugged Industrial DIN-Rail Enclosure
- Full Wire Speed Communications
- Redundant Power Inputs 10-30 VDC, 250 mA @ 24V
- RJ-45 Port Auto Negotiates Speed, Duplex, and MDIX
- UL Listed Class I, Div. 2 for Hazardous Locations
- N-View OPC Monitoring Included with -N model
- Hardened ESD Port Protection
- Order MM Part #302MC-N-XX
Order SM Part #302MCE-N-XX-YY

305FX-N

- Four RJ-45 10/100BaseTX Ports
- One 100BaseFX ST or SC Full Duplex Port
- Compact Size, Small Footprint (3.5" h x 2.1" w x 3.4" d, 0.9 lbs.)
- -20°C to 70°C Operating Temperature
- Rugged Industrial DIN-Rail Enclosure
- Full Wire Speed Communications
- Redundant Power Inputs 10-30 VDC, 250 mA @ 24V
- RJ-45 Ports Auto Negotiate Speed, Duplex, and MDIX
- UL Listed Class I, Div. 2 for Hazardous Locations
- N-View OPC Monitoring Included with -N model
- Hardened ESD Port Protection
- Order MM Part #305FX-N-XX
Order SM Part #305FXE-N-XX-YY

306FX2-N

- Four RJ-45 10/100BaseTX Ports
- Two 100BaseFX ST or SC Full Duplex Ports
- Compact Size, Small Footprint (3.5" h x 2.1" w x 3.4" d, 0.9 lbs.)
- -20°C to 70°C Operating Temperature
- Rugged Industrial DIN-Rail Enclosure
- Full Wire Speed Communications
- Redundant Power Inputs 10-30 VDC, 250 mA @ 24V
- RJ-45 Ports Auto Negotiate Speed, Duplex, and MDIX
- UL Listed Class I, Div. 2 for Hazardous Locations
- N-View OPC Monitoring Included with -N model
- Hardened ESD Port Protection
- Order MM Part #306FX2-N-XX
Order SM Part #306FXE2-N-XX-YY

Ordering Key: MM = multimode fiber, SM = singlemode fiber, "E" = singlemode fiber, "-N" = N-View OPC Switch Monitoring, leave blank for no monitoring option, "XX" = ST or SC for fiber style connector, "YY" = 15, 40, or 80 for 15km, 40km, or 80km SM fiber length.

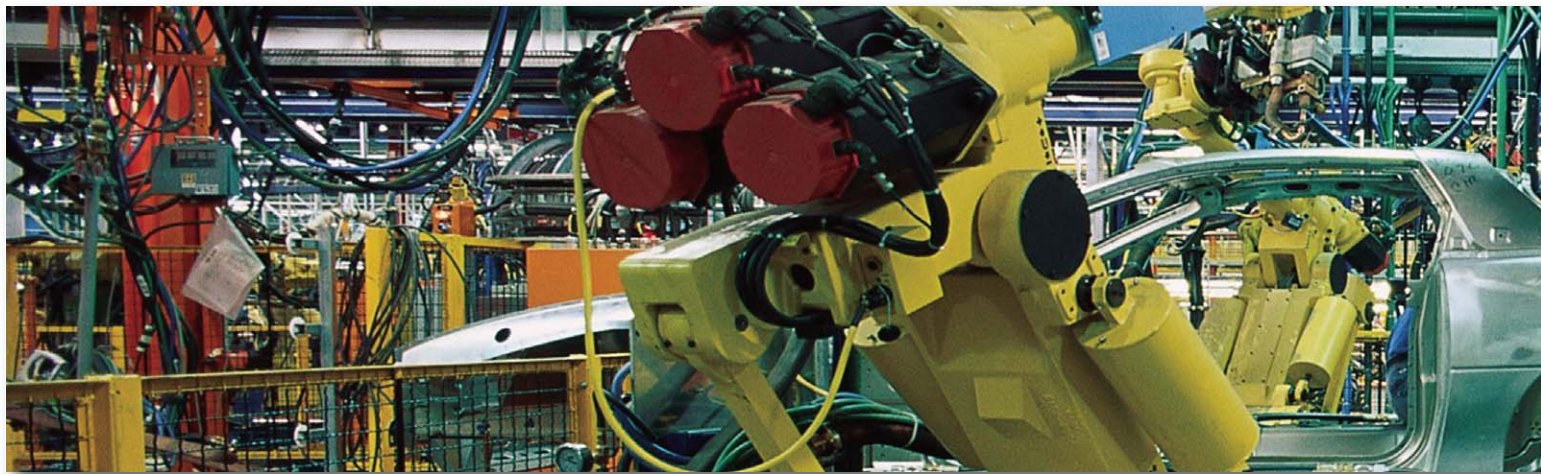

308FX2-N

- Six RJ-45 10/100BaseTX Ports
- Two 100BaseFX ST or SC Full Duplex Ports
- Case Dimensions (5.9" h x 2.3" w x 3.8" d, 1.7 lbs.)
- -40°C to 85°C Operating Temperature
- Rugged Industrial DIN-Rail Enclosure
- Full Wire Speed Communications
- Redundant Power Inputs 10-30 VDC, 380 mA @ 24V
- RJ-45 Ports Auto Negotiates Speed, Duplex, and MDIX
- UL Listed Class I, Div. 2 for Hazardous Locations
- N-View OPC Monitoring Included with -N model
- Hardened ESD Port Protection
- Order MM Part #308FX2-N-XX
Order SM Part #308FXE2-N-XX-YY

309FX-N

- Eight RJ-45 10/100BaseTX Ports
- One 100BaseFX ST or SC Full Duplex Port
- Case Dimensions (5.5" h x 2.3" w x 3.5" d, 1.6 lbs.)
- -40°C to 85°C Operating Temperature
- Rugged Industrial DIN-Rail Enclosure
- Full Wire Speed Communications
- Redundant Power Inputs 10-30 VDC, 260 mA @ 24V
- RJ-45 Ports Auto Negotiates Speed, Duplex, and MDIX
- UL Listed Class I, Div. 2 for Hazardous Locations
- N-View OPC Monitoring Included with -N model
- Hardened ESD Port Protection
- Order MM Part #309FX-N-XX
Order SM Part #309FXE-N-XX-YY

Ordering Key: "-N" = N-View OPC Switch Monitoring, leave blank for no monitoring option.



316TX-N

- Sixteen RJ-45 10/100BaseTX Ports
- Supports UTP or STP Cabling
- Case Dimensions (7.4" h x 2.3" w x 3.5" d, 1.9 lbs.)
- -40°C to 85°C Operating Temperature
- Rugged Industrial DIN-Rail Enclosure
- Full Wire Speed Communications
- Redundant Power Inputs 10-30 VDC, 400 mA @ 24V
- RJ-45 Ports Auto Negotiates Speed, Duplex, and MDIX
- UL Listed Class I, Div. 2 for Hazardous Locations
- N-View OPC Monitoring Included with -N model
- Hardened ESD Port Protection
- Order Part #316TX-N

317FX-N

- Sixteen RJ-45 10/100BaseTX Ports
- One 100BaseFX ST or SC Full Duplex Port
- Case Dimensions (7.4" h x 2.3" w x 3.5" d, 1.9 lbs.)
- -40°C to 85°C Operating Temperature
- Rugged Industrial DIN-Rail Enclosure
- Full Wire Speed Communications
- Redundant Power Inputs 10-30 VDC, 440 mA @ 24V
- RJ-45 Ports Auto Negotiates Speed, Duplex, and MDIX
- UL Listed Class I, Div. 2 for Hazardous Locations
- N-View OPC Monitoring Included with -N model
- Hardened ESD Port Protection
- Order MM Part #317FX-N-XX
Order SM Part #317FXE-N-XX-YY

Ordering Key: MM = multimode fiber, SM = singlemode fiber, "E" = singlemode fiber, "-N" = N-View OPC Switch Monitoring, leave blank for no monitoring option, "XX" = ST or SC for fiber style connector, "YY" = 15, 40, or 80 for 15km, 40km, or 80km SM fiber length.

Modular Unmanaged Fast Ethernet with Remote Monitoring (-N)

Perfect for connecting Ethernet enabled industrial equipment, such as PLC's, industrial PC's, Ethernet I/O and data acquisition equipment, the 900 Series Modular Industrial Ethernet Switch offers outstanding performance, ease of use, and flexible expansion options. Three modular slots are available for the installation of the *N-TRON* 900 Series expansion modules, providing maximum flexibility; mix and match fiber ports with twisted pair ports. Up to twenty-four twisted pair 10/100BaseTX or twelve 100BaseFX fiber ports can be installed with multiple combinations available. All 900 series switches are UL Listed for use in Class I, Division 2 Hazardous locations. The 900B Chassis draws less than 1.5 Amps of input current at 24 volts when fully populated.

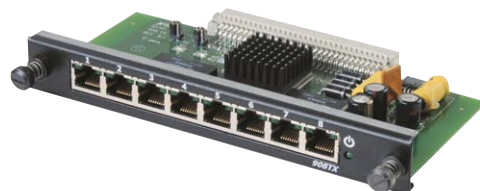

900B-N

- 3 Slot Chassis for optional expansion modules
- Rugged Industrial DIN-Rail Enclosure
- Case Dimensions (3.2" h x 7.1" w x 4.2" d, 3.0 lbs.)
- Plug-and-play Unmanaged Operation
- -20°C to 70°C Operating Temperature
- Hardened 16 Gauge Steel Construction
- UL Listed Class I, Div. 2 for Hazardous Locations
- Up to 2.6 Gb/s Aggregate Bandwidth
- Redundant Power Inputs 10-30 VDC, 200 mA @ 24V
- N-View OPC Monitoring Included with -N model
- > 2M Hours MTBF
- Order Chassis Part #900B-N
Order Filler Panel Part #900B-FP

908TX

- Slide in Module for 900 Series Chassis
- Eight RJ-45 10/100BaseTX Ports
- Module Weight 0.5 lbs
- Plug-and-play Unmanaged Operation
- -20°C to 70°C Operating Temperature
- Auto Negotiates Speed, Duplex, and MDIX
- 4,000 MAC Addresses Per Module
- Full Wire Speed Communications
- Redundant Power Inputs 10-30 VDC, 250 mA @ 24V
- Supports UTP or STP Cabling
- > 2M Hours MTBF
- Order Part #908TX

Ordering Key: -N for N-View OPC Switch monitoring, leave blank for no monitoring options.

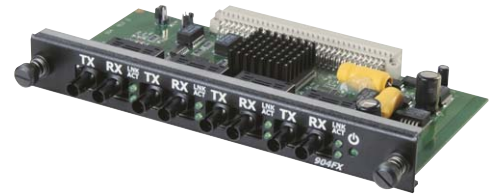
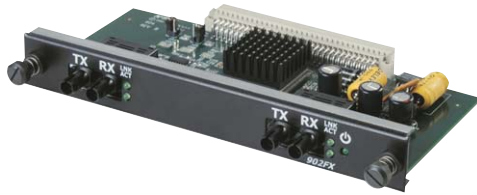

902FX

- Slide in Module for 900 Series Chassis
- Two 100BaseFX ST or SC Full Duplex Ports
- Module Weight 0.5 lbs
- Plug-and-Play Unmanaged Operation
- -20°C to 70°C Operating Temperature
- 100BaseFX Full Duplex Operation
- 4,000 MAC Addresses Per Module
- Full Wire Speed Communications
- Redundant Power Inputs 10-30 VDC, 400 mA @ 24V
- 15, 40, or 80km Fiber Length Available
- > 2M Hours MTBF
- Order MM Part #902FX-XX
Order SM Part #902FXE-XX-YY

904FX

- Slide in Module for 900 Series Chassis
- Four 100BaseFX ST or SC Full Duplex Ports
- Module Weight 0.6 lbs
- Plug-and-Play Unmanaged Operation
- -20°C to 70°C Operating Temperature
- 100BaseFX Full Duplex Operation
- 4,000 MAC Addresses Per Module
- Full Wire Speed Communications
- Redundant Power Inputs 10-30 VDC, 400 mA @ 24V
- 15, 40, or 80km Fiber Length Available
- > 2M Hours MTBF
- Order MM Part #904FX-XX
Order SM Part #904FXE-XX-YY

Ordering Key: MM = multimode fiber, SM = singlemode fiber, “E” = singlemode fiber, “XX” = ST or SC for fiber style connector, “YY” = 15, 40, or 80 for 15km, 40km, or 80km SM fiber length.

Fast Ethernet Process Control Switches with Remote Monitoring and Advanced Management



The *N-TRON* 500 Series, with the -A option, is well suited for connecting Ethernet equipped industrial control applications and comes with advanced Ethernet communication management features: like VLAN, IGMP Snooping, Port Trunking, QoS, and Mirroring. IGMP and query auto detect modes are enabled by default, and key enhancements include multiple router support as well as dynamic router discovery and master/slave redundancy for query detection. The 500 Series products are designed to withstand extreme industrial environments and come standard with extended temperature ratings, extended shock, noise, and vibration specifications, redundant power inputs and high MTBF. All 500 Series switches are supplied with the following regulatory approvals: FCC Part 15 Class A, UL 1604 C Listed (U.S. & Canada) for Class I, Div. 2 Hazardous Locations, ATEX Zone 2, Category 3G (Ex nC Mark), IEEE 1613 Compliance (Electric Utility Substation), ABS Type Approval (Maritime), and NEMA TS1/TS2 Compliance (Traffic Control).



508TX-A

- Eight RJ-45 10/100BaseTX Ports
- Supports UTP or STP Cabling
- Case Dimensions (2.3" h x 5.5" w x 3.5" d, 1.6 lbs.)
- -40°C to 85°C Operating Temperature
- Rugged Industrial DIN-Rail Enclosure
- Full Wire Speed Communications
- Redundant Power Inputs 10-30 VDC, 200 mA @ 24V
- Auto Negotiates Speed, Duplex, and MDIX
- Advanced Management Features Included with -A model
- N-View OPC Monitoring Included with -A and -N models
- Hardened ESD Port Protection
- Order Part #508TX-A

516TX-A

- Sixteen RJ-45 10/100BaseTX Ports
- Supports UTP or STP Cabling
- Case Dimensions (2.3" h x 7.4" w x 3.5" d, 1.9 lbs.)
- -40°C to 85°C Operating Temperature
- Rugged Industrial DIN-Rail Enclosure
- Full Wire Speed Communications
- Redundant Power Inputs 10-30 VDC, 400 mA @ 24V
- Auto Negotiates Speed, Duplex, and MDIX
- Advanced Management Features Included with -A model
- N-View OPC Monitoring Included with -A and -N models
- Hardened ESD Port Protection
- Order Part # 516TX-A

Ordering Key: "-A" = -A for Adv. Mgmt. Features (includes N-View), or -N for N-View OPC Switch monitoring, leave blank for Unmanaged Switch option.

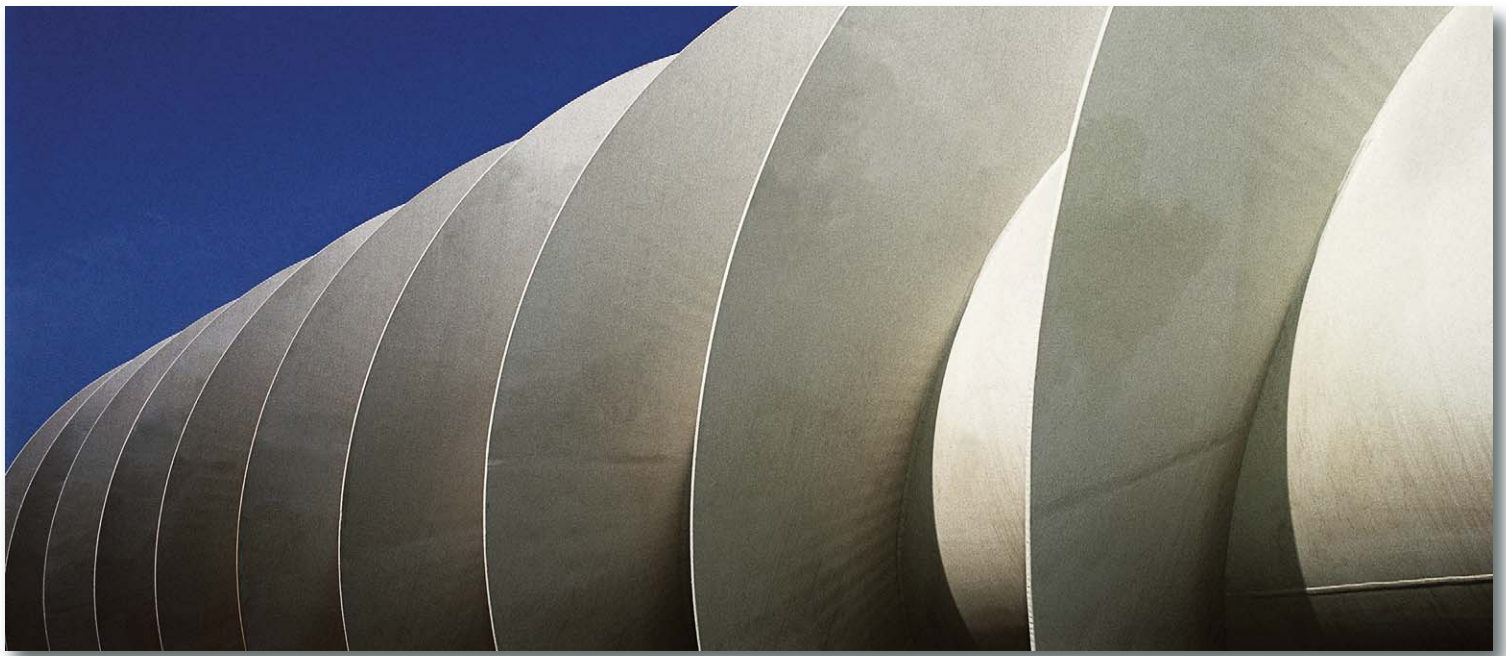

508FX2-A

- Six RJ-45 10/100BaseTX Ports
- Two 100BaseFX ST or SC Full Duplex Ports
- Case Dimensions (2.3" h x 5.9" w x 3.8" d, 1.7 lbs.)
- -40°C to 85°C Operating Temperature
- Rugged Industrial DIN-Rail Enclosure
- Full Wire Speed Communications
- Redundant Power Inputs 10-30 VDC, 380 mA @ 24V
- RJ-45 Ports Auto Negotiate Speed, Duplex, and MDIX
- Advanced Management Features Included with -A model
- N-View OPC Monitoring Included with -A and -N models
- Hardened ESD Port Protection
- Order MM Part #508FX2-A-XX-S
Order SM Part #508FXE2-A-XX-YY

509FX-A

- Eight RJ-45 10/100BaseTX Ports
- One 100BaseFX ST or SC Full Duplex Port
- Case Dimensions (2.3" h x 5.5" w x 3.5" d, 1.6 lbs.)
- -40°C to 85°C Operating Temperature
- Rugged Industrial DIN-Rail Enclosure
- Full Wire Speed Communications
- Redundant Power Inputs 10-30 VDC, 260 mA @ 24V
- RJ-45 Ports Auto Negotiate Speed, Duplex, and MDIX
- Advanced Management Features Included with -A model
- N-View OPC Monitoring Included with -A and -N models
- Hardened ESD Port Protection
- Order MM Part #509FX-A-XX-S
Order SM Part #509FXE-A-XX-YY

517FX-A

- Sixteen RJ-45 10/100BaseTX Ports
- One 100BaseFX ST or SC Full Duplex Port
- Case Dimensions (2.3" h x 7.4" w x 3.5" d, 1.9 lbs.)
- -40°C to 85°C Operating Temperature
- Rugged Industrial DIN-Rail Enclosure
- Full Wire Speed Communications
- Redundant Power Inputs 10-30 VDC, 440 mA @ 24V
- RJ-45 Ports Auto Negotiate Speed, Duplex, and MDIX
- Advanced Management Features Included with -A model
- N-View OPC Monitoring Included with -A and -N models
- Hardened ESD Port Protection
- Order MM Part #517FX-A-XX-S
Order SM Part #517FXE-A-XX-YY

Ordering Key: MM = multimode fiber, SM = singlemode fiber, "E" = singlemode fiber, "XX" = ST or SC for fiber style connector, "-S" = -S for -20°C to 70°C Operating Temp., leave blank for -40°C to 85°C Operating Temp., "YY" = 15, 40, or 80 for 15km, 40km, or 80km SM fiber length.

Built to Withstand Extreme Industrial Environments

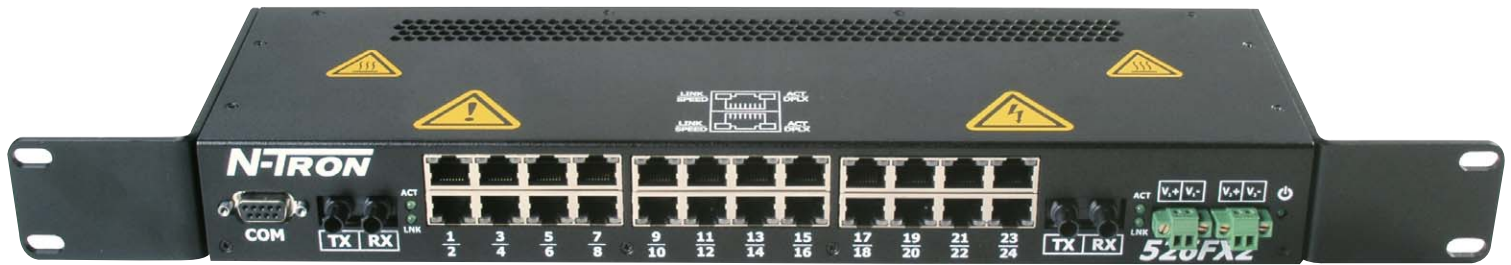

N-TRON Industrial Ethernet products come standard with extended temperature ratings, extended shock, noise and vibration specifications, redundant power inputs, and a high MTBF. Our Products are made in the U.S.A.

Three Year Warranty

All N-TRON products come with a 3 year warranty.

Call +1 (251) 342-2164 for more details.

524TX-A

- Twenty-four RJ-45 10/100BaseTX Ports
- Supports UTP or STP Cabling
- Case Dimensions (1.8" h x 19" w x 4.3" d, 3.7 lbs.)
- -40°C to 85°C Operating Temperature
- Rugged Industrial Rackmount Enclosure
- Up to 2.6 Gb/s Throughput
- Redundant Power Inputs 10-30 VDC, 720 mA @ 24V
- Auto Negotiates Speed, Duplex, and MDIX
- Advanced Management Features Included with -A model
- N-View OPC Monitoring Included with -A and -N models
- Hardened ESD Port Protection
- Order Part #524TX-A

526FX2-A

- Twenty-four RJ-45 10/100BaseTX Ports
- Two 100BaseFX ST or SC Full Duplex Ports
- Case Dimensions (1.8" h x 19" w x 4.3" d, 3.7 lbs.)
- -40°C to 85°C Operating Temperature
- Rugged Industrial Rackmount Enclosure
- Up to 2.6 Gb/s Throughput
- Redundant Power Inputs 10-30 VDC, 1 A @ 24V
- RJ-45 Ports Auto Negotiate Speed, Duplex, and MDIX
- Advanced Management Features Included with -A model
- N-View OPC Monitoring Included with -A and -N models
- Hardened ESD Port Protection
- Order MM Part #526FX2-A-XX-S
Order SM Part #526FXE2-A-XX-YY

18 **Ordering Key:** "-A" = -A for Adv. Mgmt. Features (includes N-View), or -N for N-View OPC Switch monitoring, leave blank for Unmanaged Switch option. MM = multimode fiber, SM = singlemode fiber, "E" = singlemode fiber, "XX" = ST or SC for fiber style connector, "-S" = -S for -20°C to 70°C Operating Temp., leave blank for -40°C to 85°C Operating Temp., "YY" = 15, 40, or 80 for 15km, 40km, or 80km SM fiber length.



N-TRON Advanced Management Features

Ordering Tip: Must Specify 500-A, 700, 7000, or 9000 Series models to receive Advanced Management Features

N-TRON's Advanced management features are standard on the **500 Series with the -A option**, and our fully managed **700, 7000, and 9000 Series Switches**. The **500-A Switches** are configured using the serial COM port, while the **700, 7000, and 9000 Switches** are configured using a Web Browser, SNMP, or COM port. The **-A option** must be specified when ordering **500 Series Switches** to receive advanced management features.

IGMP Snooping - The Internet Group Management Protocol feature allows IGMP capable switches to forward multicast traffic based on learned group addresses. IGMP Snooping and query auto detect modes are enabled by default. IGMP features include dynamic router discovery and master/slave redundancy for query detection. The ability to automatically detect bi-directional router ports and seamlessly form IGMP groups across multiple switches in a N-TRON network reduces, and in some cases completely eliminates the need to configure the switch via the Command Line Interface in most Ethernet control networks.

VLAN - Virtual Local Area Network allows the segmentation of the network in order to create two or more separate or overlapping local area network domains.

N-TRON Industrial Ethernet switches with advanced management features can be setup for IEEE 802.1Q dynamic tagged VLAN, or pre-determined port VLAN.

QoS - The Quality of Service feature provides prioritization of network traffic in order to provide better network service. The primary goal of QoS is to minimize the latency of prioritized Ethernet packets required for ring management, real-time, and other interactive applications.

Trunking - Also known as link aggregation, Trunking allows multiple physical ports to be linked together and function as one uplink to another Trunking capable switch configured in the same manner. The Trunking feature will increase the bandwidth between two switches and provides media redundancy.

Port Mirroring - This function allows the traffic on one port to be duplicated and sent to a designated mirror port. Port mirroring can be used to monitor Ethernet traffic on the designated source port using the assigned mirror port.

Port Control - N-TRON switch ports can be enabled or disabled and may be individually configured for full or half duplex, 10Mb/s or 100Mb/s.

Rapid Spanning Tree - This feature permits the **700, 7000 or 9000 Series switches** to be configured in a Ring or Mesh topology, and provides support for redundant path communications with rapid healing.

N-View OPC Server Software

N-ViewOPC

Selected Network Card (Adapter): Intel® Pro/100 VE Network Connection

Buttons: Import, Export, Save & Close, Close, Don't Save

Current Switches

Each switch that is not shown in the right side list must be mapped to a switch model in the box below

516TX [Map]

To Change the switch alias select the switch in the right side list type in the new alias name in the box below and press '>>'.

STA # 023 [>>]

To delete a switch highlight it and press '<<'.

[<<]

Switch - Alias Name

00.07.AF.00.06.09	MCC # 001
00.07.AF.00.06.10	MCC # 002
00.07.AF.00.06.11	MCC # 003
00.07.AF.00.06.12	MCC # 004
00.07.AF.00.06.13	BLG # 001
00.07.AF.00.06.14	BLG # 004
00.07.AF.00.06.15	BLG # 037
00.07.AF.00.06.0A	STA # 023

Buttons: Switch Details, Data Format (String, Integer)

The *N-TRON N-View™* OLE for Process Control (OPC) Server Software will work with industry standard OPC Client software and most popular Human Machine Interface (HMI) packages, providing complete remote network traffic and status monitoring for *N-TRON* 200, 300, 400, 500, and 900 Series Industrial Switches with the N-View Firmware option. N-View is available as a standard feature on all 700, 7000, and 9000 Series Switches.

The N-View OPC Server in combination with one or more of our industrial switches will add complete network visibility to an HMI Control and Monitoring application.

Ports

Adapter: Intel® Pro/100 VE Network Connection

Switch: STA # 023

Ports:

- PLC # 001
- DRV # 001
- DRV # 002
- DRV # 003
- DRV # 004
- DRV # 005
- DRV # 006
- HMI # 001
- HMI # 002
- PLC # 002
- PORT 11
- PORT 12
- PORT 13
- PORT 14
- PORT 15
- PORT 16

Buttons: Close, Hide Port, View Switch, View Ports

To Change the switch alias select the switch in the right side list type in the new alias name in the box below and press '>>' Button.

DRV # 007 [>>]

N-View Switch Firmware

N-TRON Switches with the N-View firmware upgrade (part numbers with -A or -N extensions) will autocast a small Ethernet packet periodically containing port-by-port status of the switch. This information includes 5 switch level data points and 41 data points per port. This data is captured by the N-View OPC Server Software and can be displayed by application software running in the same Windows environment with OPC Client capability.

Ease of Use

The *N-TRON* N-View Software includes the OPC Server and a configuration and monitoring software utility. This utility will automatically search the network for all N-View enabled switches using the unique IEEE MAC addresses to identify each switch. The switch MAC address can be selected and assigned an 80 character alias name. Meaningful alias names can also be added to all ports using the configuration software. The switch and port alias names can be saved and used by the N-View OPC Server as part of the switch variable names. The alias names can be used to help identify the location of the switch and the areas or equipment connected to the ports.

Switch: STA # 023
 IP Address: 192.168.1.61
 N-Ring Version: 1 N-Ring Member: No
 N-Ring Manager: Yes N-Ring State: Ok

Ports:	Links:	Speed:	Duplex:
PLC # 001	UP	100	FULL
DRV # 001	DOWN	NA	NA
DRV # 002	UP	100	FULL
DRV # 003	UP	100	FULL
DRV # 004	UP	100	FULL
DRV # 005	UP	100	FULL
DRV # 006	DOWN	NA	NA
HMI # 001	UP	10	HALF
HMI # 002	UP	10	HALF
PLC # 002	UP	100	FULL
I/O # 001	UP	100	FULL
I/O # 002	DOWN	NA	NA
DRV # 007	UP	100	FULL
DRV # 008	UP	100	FULL
I/O #003	UP	100	FULL
CAM # 003	UP	10	HALF

N-View OPC Data Variables

N-View OPC Server data variables can be accessed using N-View monitoring utility, or most popular HMI application software packages with OPC client capability. These variables can be divided into three general categories: **Status variables** indicate the operating condition of the switch or port; **Traffic variables** count the number of OCTETS (BYTES) of a specific type of Ethernet packet that have passed through a port since the start of the switch; and **Error variables** count the number of packet errors seen at each port since the start of the switch. HMI software packages can convert these variables to the data type required for display, alarming, and trending during the data scan update process.

Switch: STA # 023
 IP Address: 192.168.1.61
 Port: DRV # 007
 Speed: 100 Link: Up N-Ring Version: 1 N-Ring Member: No
 Duplex: Full Enable: Yes N-Ring Manager: Yes N-Ring State: Ok

Usage: 0 100% Select the port from the list below:

Tx Octets	4052024	Rx Octets	39844501556
Tx Dropped Packets	0	Rx Dropped Packets	0
Tx Broadcast Packets	568	Rx Broadcast Packets	0
Tx Multicast Packets	14346	Rx Multicast Packets	9
Tx Unicast Packets	2992	Rx Unicast Packets	17890849
Tx Collisions	0	Rx Undersize Packets	0
Tx Single Collision	0	Rx Oversize Packets	0
Tx Mutiple Collision	0	Rx Jabbers	0
Tx Deferred	0	Rx Alignment Errors	0
Tx Late Collision	0	Rx Good Octets	3984501780
Tx Excessive	0	Rx SA Changes	0
Tx Frame In Disc	0	Rx FCS Errors	0
Tx Pause Packets	0	Rx Pause Packets	0
64 Packets	264937	Rx Fragments	0
65 to 127 Packets	2545888	RX Excessive Disc Size	101606610
128 to 255 Packets	10160661	Rx Symbol Errors	0
256 to 511 Packets	1442929	1024 to 1522 Packets	0
512 to 1023 Packets	3740131		

PLC # 001
 DRV # 001
 DRV # 002
 DRV # 003
 DRV # 004
 DRV # 005
 DRV # 006
 HMI # 001
 HMI # 002
 PLC # 002
 I/O # 001
 I/O # 002
 DRV # 007
 DRV # 008
 I/O #003
CAM # 003

Industrial Wireless Ethernet with IEEE 802.11 a,b,g,n

N-TRON's 702-W and 702M12-W Industrial Wireless Ethernet Radios offers unprecedented throughput in industrial wireless applications. IEEE 802.11n support allows these radios to utilize three antennas and Multiple In, Multiple Out (MIMO) technology for increased throughput, yielding much higher data rates than devices supporting only 802.11a/b/g. *N-TRON's* wireless devices also support 802.11a/b/g compatibility for existing wireless networks. The 702M12-W's IP67 rated enclosure with M12 connectors provides complete protection against dust, water jets, and temporary immersion in water making it ideal for outdoor, wash down, or extremely dusty environments. Power over Ethernet (PoE) technology allows the 702-W or 702M12-W to receive power through the Cat5e cable from a PoE sourcing device such as *N-TRON's* 105TX-POE Switch. Network deployments are much easier using wireless and PoE technology because only one Cat5e cable is required. These radios are UL Listed for use in Class I, Division 2 Hazardous locations.



702-W

- One 10/100BaseTX RJ-45 Port
- Three Antennas for 3x3 MIMO Operations
- 802.3af PoE Powered Device
- Case Dimensions (4.8" h x 7.0" w x 1.2" d, 1.9 lbs.)
- -40°C to 70°C Operating Temperature
- Web Browser Management
- Data Rates: Legacy 802.11a/b/g = 1-54Mbps
802.11n = up to 300Mbps
- Network Modes: Bridge or Router
- Wireless Modes: Station, Station WDS
Access Point, Access Point WDS
- Range: Indoor greater than 300m*
Outdoor greater than 60km*
- Security: 802.11i with AES-CCM & TKIP Encryption
802.1x, 64/128 bit WEP
- Redundant Power Inputs 20-49 VDC, 200mA @ 24V
- Order Part #702-W

702M12-W

- One 10/100BaseTX M12 Port
- IP67 Rated Enclosure - Protected Against Dust, Low/High Pressure Water Jets and Temporary Immersion in Water
- 802.3af PoE Powered Device
- Case Dimensions (6.7" h x 6.7" w x 1.8" d, 3.5 lbs.)
- -40°C to 70°C Operating Temperature
- Web Browser Management
- Data Rates: Legacy 802.11a/b/g = 1-54Mbps
802.11n = up to 300Mbps
- Network Modes: Bridge or Router
- Wireless Modes: Station, Station WDS
Access Point, Access Point WDS
- Range: Indoor greater than 300m*
Outdoor greater than 60km*
- Security: 802.11i with AES-CCM & TKIP Encryption
802.1x, 64/128 bit WEP
- Redundant Power Inputs 20-49 VDC, 200mA @ 24V
- Order Part #702M12-W

IP67 Rated Fully Managed Ethernet

Housed in an IP67 rated metal enclosure, the fully managed 708M12 is ideally suited for connecting Ethernet enabled devices in railway, industrial, marine, and security applications. The IP67 rated enclosure provides protection against dust, low and high pressure water jets, and temporary immersion in water. All 708M12 models are EN50155 certified for railway applications. Standard voltage models are UL Listed for use in Class I, Division 2 hazardous locations and have ABS and DNV Type Approval for maritime environments. High voltage models are TÜV/GS certified.



708M12

- Eight 10/100BaseTX M12-D Coded Ports
- IP67 Rated for Protection Against Dust, Water Jets, and Temporary Immersion in Water
- Case Dimensions (6.7" h x 6.7" w x 1.8" d, 3.4 lbs.)
- -40°C to 80°C Operating Temperature
- SNMP v1, v2, v3, and Web Configuration including MAC Filters and IGMP Groups
- GUI Based DHCP Server with Option 61, Option 82 Relay Agent, Local IP Static Addressing, and IP Fallback
- *N-Link* Redundant *N-Ring* Coupling
- Port Security - MAC Address Based
- Adv. Features: IGMP Auto Config., VLAN, QoS, Trunking, Mirroring, 802.1D RSTP, LLDP, & EtherNet/IP CIP Messaging
- Ring Manager using *N-TRON's N-Ring* Technology offers a Standard Healing Time of ~30ms
- N-View OPC Monitoring with Fault Status for Ring Managers
- Redundant Power Inputs 10-30 VDC, 250mA @ 24V, or 40-160 VDC, 62mA @ 124 V for High Voltage Model
- Order Part #708M12 or 708M12-HV for High Voltage Model

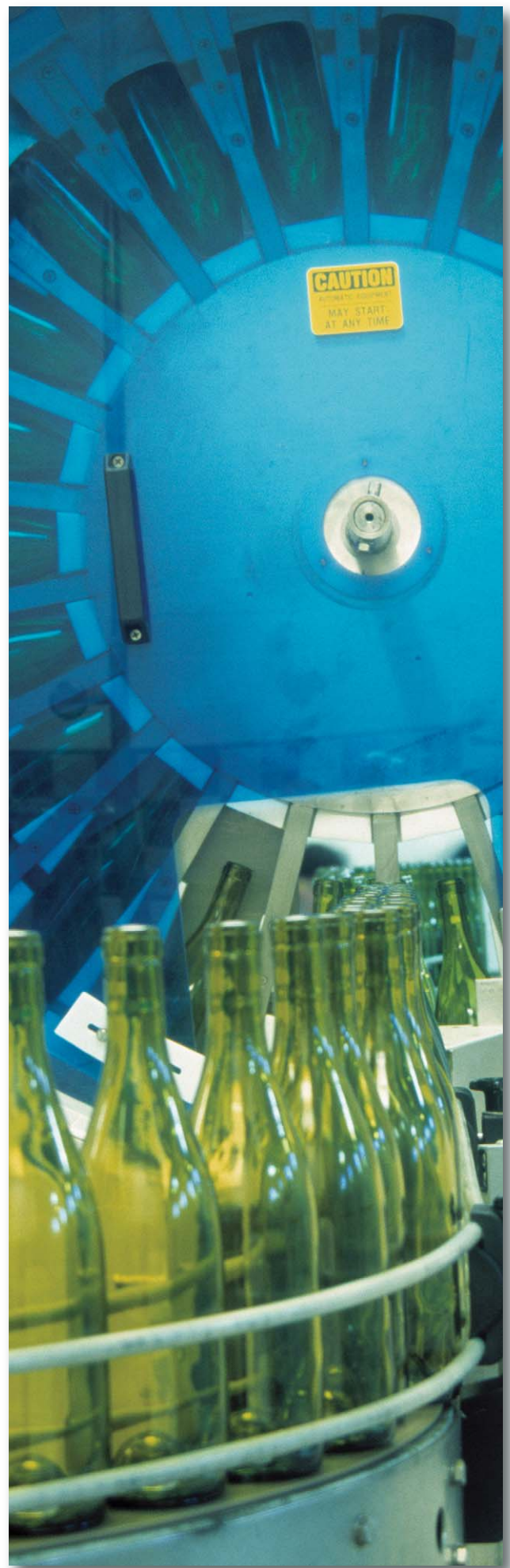

Fully Managed Fast Ethernet with SNMP V3 & DHCP Server Option 82

The *N-TRON* 700 Series Fully Managed Industrial Fast Ethernet Switches are affordably priced to fit any networking budget while offering outstanding management and monitoring features. They are ideally suited for use as a Ring Manager or anywhere a managed switch is required. The 700 Series comes standard with fully managed features like plug-and-play IGMP Snooping, VLAN, QoS, Port Mirroring, Port Trunking, 802.1D RSTP, DHCP Server with Option 82, and *N-Ring*. When used as a Ring Manager, *N-TRON's N-Ring* technology provides detailed fault diagnostics, expanded ring size capacity, and ~30ms ring healing. Added control features such as full SNMP V3, Web Browser Management, and N-View OPC Remote Monitoring provide all of the tools necessary to simplify configuration and diagnostics of the *N-TRON* switches. The Industrially hardened construction of the 700 series results in an impressive operating temperature of -40°C to 70°C or above allowing them to be placed in the harshest of applications. All models below are EN50155 certified for railway applications. Standard voltage models are UL Listed for use in Class I, Division 2 hazardous locations. High voltage models are TÜV/GS certified. In addition to ATEX Type Certification, the 708TX and 708FX2 have ABS and DNV Type Approval for maritime environments.



ABB Industrial IT™ Certified

708TX

- Eight 10/100BaseTX RJ-45 Copper Ports
- Auto Sensing 10/100BaseTX, Duplex, and MDIX
- Case Dimensions (2.3" h x 6.0" w x 3.8" d, 1.7 lbs.)
- -40°C to 85°C Operating Temperature
- SNMP v1, v2, v3, and Web Configuration including MAC Filters and IGMP Groups
- GUI Based DHCP Server with Option 61, Option 82 Relay Agent, Local IP Static Addressing, and IP Fallback
- *N-Link* Redundant *N-Ring* Coupling
- Port Security - MAC Address Based
- Adv. Features: IGMP Auto Config., VLAN, QoS, Trunking, Mirroring, 802.1D RSTP, LLDP, & EtherNet/IP CIP Messaging
- Ring Manager using *N-TRON's N-Ring* Technology offers a Standard Healing Time of ~30ms
- N-View OPC Monitoring with Fault Status for Ring Managers
- Redundant Power Inputs 10-30 VDC, 250mA @ 24V
- Order Part #708TX

708FX2

- Six 10/100BaseTX RJ-45 Copper Ports
- Two 100BaseFX ST or SC Full Duplex Ports
- Case Dimensions (2.3" h x 6.0" w x 3.8" d, 1.7 lbs.)
- -40°C to 85°C Operating Temperature
- SNMP v1, v2, v3, and Web Configuration including MAC Filters and IGMP Groups
- GUI Based DHCP Server with Option 61, Option 82 Relay Agent, Local IP Static Addressing, and IP Fallback
- *N-Link* Redundant *N-Ring* Coupling
- Port Security - MAC Address Based
- Adv. Features: IGMP Auto Config., VLAN, QoS, Trunking, Mirroring, 802.1D RSTP, LLDP, & EtherNet/IP CIP Messaging
- Ring Manager using *N-TRON's N-Ring* Technology offers a Standard Healing Time of ~30ms
- N-View OPC Monitoring with Fault Status for Ring Managers
- Redundant Power Inputs 10-30 VDC, 330mA @ 24V
- Order MM Part #708FX2-XX
Order SM Part #708FXE2-XX-YY



716TX

- Sixteen 10/100BaseTX RJ-45 Copper Ports
- Auto Sensing 10/100BaseTX, Duplex, and MDIX
- Case Dimensions (2.3" h x 8.3" w x 4.8" d, 3.3 lbs.)
- -40°C to 70°C Operating Temperature
- SNMP v1, v2, v3, and Web Configuration including MAC Filters and IGMP Groups
- GUI Based DHCP Server with Option 61, Option 82 Relay Agent, Local IP Static Addressing, and IP Fallback
- *N-Link* Redundant *N-Ring* Coupling
- Port Security - MAC Address Based
- Adv. Features: IGMP Auto Config., VLAN, QoS, Trunking, Mirroring, 802.1D RSTP, LLDP, & EtherNet/IP CIP Messaging
- Ring Manager using *N-TRON's N-Ring* Technology offers a Standard Healing Time of ~30ms
- N-View OPC Monitoring with Fault Status for Ring Managers
- Redundant Power Inputs: 10-30 VDC, 620mA @ 24V, or 40-160 VDC, 160mA @ 124V for High Voltage Model
- Order Part #716TX or #716TX-HV for High Voltage Model

716FX2

- Fourteen 10/100BaseTX RJ-45 Copper Ports
- Two 100BaseFX ST or SC Full Duplex Ports
- Case Dimensions (2.3" h x 8.3" w x 4.8" d, 3.3 lbs.)
- -40°C to 70°C Operating Temperature
- SNMP v1, v2, v3, and Web Configuration including MAC Filters and IGMP Groups
- GUI Based DHCP Server with Option 61, Option 82 Relay Agent, Local IP Static Addressing, and IP Fallback
- *N-Link* Redundant *N-Ring* Coupling
- Port Security - MAC Address Based
- Adv. Features: IGMP Auto Config., VLAN, QoS, Trunking, Mirroring, 802.1D RSTP, LLDP, & EtherNet/IP CIP Messaging
- Ring Manager using *N-TRON's N-Ring* Technology offers a Standard Healing Time of ~30ms
- N-View OPC Monitoring with Fault Status for Ring Managers
- Redundant Power Inputs: 10-30 VDC, 620mA @ 24V, or 40-160 VDC, 160mA @ 124V for High Voltage Models
- Order MM Part #716FX2-XX-VV
Order SM Part #716FXE2-XX-YY-VV

Ordering Key: MM = multimode fiber, SM = singlemode fiber, "E" = singlemode fiber, "XX" = *ST* or *SC* for fiber style connector, "YY" = 15, 40, or 80 for 15km, 40km, or 80km SM fiber length, "VV" = *HV* for High voltage option, otherwise leave blank

Compact Fully Managed Ethernet with Multiple Fiber Ports for Long Distance Operation

Housed in compact, hardened enclosures, the 709FX, 710FX2, 711FX3, 712FX4, 714FX6, and 7010TX were designed to meet the rigorous requirements of wind farms, utilities, (including power substations), and other industrial process control applications where noise immunity and support for longer distances are essential. Packed with *N-TRON's* robust fully managed feature set - Port Security, IGMP Snooping, VLAN, QoS, Port Mirroring, Port Trunking, 802.1D RSTP, DHCP Server with Option 82, and N-Ring, this fully managed series offers up to six fiber ports providing the ability to configure fiber rings and fiber uplinks, in a small, very cost effective solution. The 7010TX also offers two Gigabit SFP expansion ports for optional Multimode and Singlemode fiber or 1000BaseT copper connections. For added convenience, an optional SD card may be purchased for saving or restoring the switch configuration. Standard voltage models are UL Listed for use in Class I, Division 2 hazardous locations. High voltage models are TÜV/GS certified.



709FX

- Eight RJ-45 10/100BaseTX Ports
- One 100BaseFX, ST or SC Full Duplex Port
- DIN-Rail Case Dimensions (4.3" h x 2.4" w x 4.6" d, 1.4 lbs.)
- -40°C to 70°C Operating Temp. Includes Onboard Temp Sensor
- Redundant Power: 10-49 VDC, 365 mA @ 24V, or 43-300 VDC, 95mA @ 124V for HV
- Port Security - MAC Address Based
- DHCP Server, Option 82 relay, Option 61, and IP Fallback
- SNMP v1, v2, v3 and Web Browser Management
- N-View OPC Monitoring with Fault Status for Ring Managers
- IGMP Auto Config., VLAN, LLDP, QoS, Trunking, Mirroring
- 802.1D RSTP, *N-Link*, *N-Ring*, EtherNet/IP CIP Messaging
- Order MM Part #709FX-XX-VV
Order SM Part #709FXE-XX-YY-VV

710FX2

- Eight RJ-45 10/100BaseTX Ports
- Two 100BaseFX, ST or SC Full Duplex Ports
- DIN-Rail Case Dimensions (4.3" h x 2.4" w x 4.6" d, 1.4 lbs.)
- -40°C to 70°C Operating Temp. Includes Onboard Temp Sensor
- Redundant Power: 10-49 VDC, 415 mA @ 24V, or 43-300 VDC, 100mA @ 124V for HV
- Port Security - MAC Address Based
- DHCP Server, Option 82 relay, Option 61, and IP Fallback
- SNMP v1, v2, v3 and Web Browser Management
- N-View OPC Monitoring with Fault Status for Ring Managers
- IGMP Auto Config., VLAN, LLDP, QoS, Trunking, Mirroring
- 802.1D RSTP, *N-Link*, *N-Ring*, EtherNet/IP CIP Messaging
- Order MM Part #710FX2-XX-VV
Order SM Part #710FXE2-XX-YY-VV

711FX3

- Eight RJ-45 10/100BaseTX Ports
- Three 100BaseFX, ST or SC Full Duplex Ports
- DIN-Rail Case Dimensions (4.3" h x 2.4" w x 4.6" d, 1.4 lbs.)
- -40°C to 70°C Operating Temp. Includes Onboard Temp Sensor
- Redundant Power: 10-49 VDC, 455mA @ 24V or 43-300 VDC, 105mA @ 124V for HV
- Port Security - MAC Address Based
- DHCP Server, Option 82 relay, Option 61, and IP Fallback
- SNMP v1, v2, v3 and Web Browser Management
- N-View OPC Monitoring with Fault Status for Ring Managers
- IGMP Auto Config., VLAN, LLDP, QoS, Trunking, Mirroring
- 802.1D RSTP, *N-Link*, *N-Ring*, EtherNet/IP CIP Messaging
- Order MM Part #711FX3-XX-VV
Order SM Part #711FXE3-XX-YY-VV



712FX4

- Eight RJ-45 10/100BaseTX Ports
- Four 100BaseFX, ST or SC Full Duplex Ports
- DIN-Rail Case Dimensions (4.3" h x 3.1" w x 4.6" d, 1.8 lbs.)
- -40°C to 70°C Operating Temp. Includes Onboard Temp Sensor
- Redundant Power: 10-49 VDC, 505 mA @ 24V or 43-300 VDC, 125mA @ 124V for HV
- Port Security - MAC Address Based
- DHCP Server, Option 82 relay, Option 61, and IP Fallback
- SNMP v1, v2, v3 and Web Browser Management
- N-View OPC Monitoring with Fault Status for Ring Managers
- IGMP Auto Config., VLAN, LLDP, QoS, Trunking, Mirroring
- 802.1D RSTP, *N-Link*, *N-Ring*, EtherNet/IP CIP Messaging
- Order MM Part #712FX4-XX-VV
Order SM Part #712FXE4-XX-YY-VV

714FX6

- Eight RJ-45 10/100BaseTX Ports
- Six 100BaseFX, ST or SC Full Duplex Ports
- DIN-Rail Case Dimensions (4.3" h x 3.1" w x 4.6" d, 1.8 lbs.)
- -40°C to 70°C Operating Temp. Includes Onboard Temp Sensor
- Redundant Power Inputs 10-49 VDC, 610 mA @ 24V
- Port Security - MAC Address Based
- DHCP Server, Option 82 relay, Option 61, and IP Fallback
- SNMP v1, v2, v3 and Web Browser Management
- N-View OPC Monitoring with Fault Status for Ring Managers
- IGMP Auto Config., VLAN, LLDP, QoS, Trunking, Mirroring
- 802.1D RSTP, *N-Link*, *N-Ring*, EtherNet/IP CIP Messaging
- Order MM Part #714FX6-XX
Order SM Part #714FXE6-XX-YY

7010TX

- Eight RJ-45 10/100BaseTX Ports
- Two Optional 1000BaseSX/LX/T Gigabit SFP Transceivers
- DIN-Rail Case Dimensions (4.3" h x 2.4" w x 4.6" d, 1.4 lbs.)
- -40°C to 70°C Operating Temp. Includes Onboard Temp Sensor
- Redundant Power Inputs 10-49 VDC, 410 mA @ 24V
- Port Security - MAC Address Based
- DHCP Server, Option 82 relay, Option 61, and IP Fallback
- SNMP v1, v2, v3 and Web Browser Management
- N-View OPC Monitoring with Fault Status for Ring Managers
- IGMP Auto Config., VLAN, LLDP, QoS, Trunking, Mirroring
- 802.1D RSTP, *N-Link*, *N-Ring*, EtherNet/IP CIP Messaging
- Order Part #7010TX
See page 43 for SFP options



Products shown with optional Gigabit SFP Transceivers installed



7014TX

- Twelve 10/100BaseTX RJ-45 Copper Ports
- Two Optional Full Duplex 1000BaseSX/LX Gigabit SFPs, or Two Optional 1000BaseT Gigabit SFP Transceivers
- Rugged Industrial DIN-Rail Enclosure
- Case Dimensions (2.5" h x 7.4" w x 4.2" d, 2.1 lbs.)
- -20°C to 70°C Operating Temperature
- Ring Manager using *N-TRON's N-Ring* Technology offers a Standard Healing Time of ~30ms
- Up to 250 Fully Managed *N-TRON* Switches can Participate in *N-Ring* Topology
- Full SNMP and Web Browser Management with Detailed Ring Map and Fault Location Charting
- N-View OPC Monitoring with Fault Status for Ring Managers
- Adv. Features: IGMP Auto Config., VLAN, QoS, Trunking, Mirroring, 802.1D-2004 RSTP, DHCP, SNMP, and *N-Ring*
- Redundant Power Inputs 10-30 VDC, 1A @ 24V
- Order Part #7014TX
Order TX Gigabit SFP Transceiver Part #NTSFP-TX
- Order MM Gigabit SFP Transceiver Part #NTSFP-SX
Order SM Gigabit SFP Transceiver Part #NTSFP-LX-ZZ

7014FX2

- Ten 10/100BaseTX RJ-45 Copper Ports
- Two 100BaseFX Full Duplex Fiber Optic Ports
- Two Optional Full Duplex 1000BaseSX/LX Gigabit SFPs, or Two Optional 1000BaseT Gigabit SFP Transceivers
- Case Dimensions (2.5" h x 7.4" w x 4.2" d, 2.1 lbs.)
- -20°C to 70°C Operating Temperature
- Optic Ring Manager using *N-TRON's N-Ring* Technology offers a Standard Healing Time of ~30ms
- Up to 250 Fully Managed *N-TRON* Switches can Participate in *N-Ring* Topology
- Full SNMP and Web Browser Management with Detailed Ring Map and Fault Location Charting
- N-View OPC Monitoring with Fault Status for Ring Managers
- Adv. Features: IGMP Auto Config., VLAN, QoS, Trunking, Mirroring, 802.1D-2004 RSTP, DHCP, SNMP, and *N-Ring*
- Redundant Power Inputs 10-30 VDC, 1A @ 24V
- Order MM Part #7014FX2-XX, or SM Part #7014FXE2-XX-YY
Order TX Gigabit SFP Transceiver Part #NTSFP-TX
- Order MM Gigabit SFP Transceiver Part #NTSFP-SX
Order SM Gigabit SFP Transceiver Part #NTSFP-LX-ZZ

Ordering Key: MM = multimode fiber, SM = singlemode fiber, "E" = singlemode fiber, "XX" = ST or SC for fiber style connector, "YY" = 15, 40, or 80 for 15km, 40km, or 80km SM fiber length, "ZZ" = 10, 40, or 80 for 10km, 40km, or 80km Gigabit Singlemode fiber length.

Fully Managed Gigabit Ethernet with SNMP V3 & DHCP

The *N-TRON* 7000 Series is ideal for use as either a fully managed fiber optic Ring Manager or Ring Member. These gigabit capable industrial Ethernet switches carry *N-TRON's* exclusive *N-Ring™* technology providing detailed fault diagnostics, expanded ring size capacity, and ~30ms ring healing. When using all *N-TRON* fully managed switches in a ring, a detailed ring map and fault location chart will be provided on the Ring Manager's web browser and OPC Server to identify the health status of the ring. In addition to *N-Ring*, the 7000 Series offers fully managed features such as IGMP Snooping, VLAN, QoS, Port Mirroring, Port Trunking, 802.1D-2004 fast RSTP, DHCP and *N-Ring*. For ease of monitoring, configuration, and diagnostics *N-TRON's* N-View OPC Server Software, SNMP V3, and Web Browser Management come standard on all 7000 Series Switches. N-View can be combined with popular HMI software packages to add network traffic monitoring, trending, and alarming to any application using *N-TRON* switches. For added bandwidth and flexibility, the 7000 Series provides two optional Gigabit fiber or copper SFP transceivers, installable in our factory at the time of purchase or upgraded later in the field. Standard voltage models are UL Listed for use in Class I, Division 2 hazardous locations. High voltage models are TÜV/GS certified.



7018TX

- Sixteen 10/100BaseTX RJ-45 Copper Ports
- Up to Two Optional Full Duplex 1000BaseSX/LX Gigabit and/or Two Optional 1000BaseT Gigabit SFP Transceivers
- Auto Sensing 10/100BaseTX, Duplex, and MDIX
- Case Dimensions (2.3" h x 8.3" w x 4.8" d, 3.3 lbs.)
- -40°C to 70°C Operating Temperature
- SNMP v1, v2, v3, and Web Configuration including MAC Filters and IGMP Groups
- GUI Based DHCP Server with Option 61, Option 82 Relay Agent, Local IP Static Addressing, and IP Fallback
- *N-Link* Redundant *N-Ring* Coupling plus N-View OPC Monitoring with Fault Status for Ring Mgrs.
- Port Security - MAC Address Based
- Adv. Features: IGMP Auto Config., VLAN, QoS, Trunking, Mirroring, 802.1D RSTP, LLDP, & EtherNet/IP CIP Messaging
- Ring Manager using *N-TRON's* *N-Ring* Technology offers a Standard Healing Time of ~30ms
- Redundant Power Inputs: 10-30 VDC, 520mA @ 24V, or 40-160 VDC, 160mA @ 124V for High Voltage Model
- Order Part #7018TX or #7018TX-HV for High Voltage Model
Order TX Gigabit SFP Transceiver Part #NTSFP-TX
- Order MM Gigabit SFP Transceiver Part #NTSFP-SX
Order SM Gigabit SFP Transceiver Part #NTSFP-LX-ZZ

7018FX2

- Fourteen 10/100BaseTX RJ-45 Copper Ports
- Two 100BaseFX Full Duplex Fiber Optic Ports
- Up to Two Optional Full Duplex 1000BaseSX/LX Gigabit and/or Two Optional 1000BaseT Gigabit SFP Transceivers
- Case Dimensions (2.3" h x 8.3" w x 4.8" d, 3.3 lbs.)
- -40°C to 70°C Operating Temperature
- SNMP v1, v2, v3, and Web Configuration including MAC Filters and IGMP Groups
- GUI Based DHCP Server with Option 61, Option 82 Relay Agent, Local IP Static Addressing, and IP Fallback
- *N-Link* Redundant *N-Ring* Coupling plus N-View OPC Monitoring with Fault Status for Ring Mgrs.
- Port Security - MAC Address Based
- Adv. Features: IGMP Auto Config., VLAN, QoS, Trunking, Mirroring, 802.1D RSTP, LLDP, & EtherNet/IP CIP Messaging
- Ring Manager using *N-TRON's* *N-Ring* Technology offers a Standard Healing Time of ~30ms
- Redundant Power Inputs: 10-30 VDC, 520mA @ 24V, or 40-160 VDC, 160mA @ 124V for High Voltage Models
- Order MM Part #7018FX2-XX-VV, or SM Part #7018FXE2-XX-YY-VV
Order TX Gigabit SFP Transceiver Part #NTSFP-TX
- Order MM Gigabit SFP Transceiver Part #NTSFP-SX
Order SM Gigabit SFP Transceiver Part #NTSFP-LX-ZZ

Ordering Key: MM = multimode fiber, SM = singlemode fiber, "E" = singlemode fiber, "XX" = ST or SC for fiber style connector, "YY" = 15, 40, or 80 for 15km, 40km, or 80km SM fiber length, "VV" = HV for High voltage option, otherwise leave blank, "ZZ" = 10, 40, or 80 for 10km, 40km, or 80km Gigabit Singlemode fiber length.

EtherNet/IP with CIP Messaging

N-TRON provides the convenience of CIP™ messaging for device management and monitoring with all of the benefits of *N-TRON's* robust line of fully managed Hardened Industrial Switches.

EtherNet/IP,™ better known as the Common Industrial Protocol (CIP), was designed for use in process control and industrial automation applications. CIP was designed to provide consistent device access to eliminate the need for vendor specific software for configuration and monitoring of individual devices. With embedded support for CIP, *N-TRON* switches deliver information and configuration access directly to Programmable Logic Controllers (PLC's) and HMI's (Human Machine Interface) through standard CIP messaging. Switch status, trending and configuration are easily viewed from a PanelView Plus with screen resolutions of 640 x 480 and higher. In addition to CIP, *N-TRON's* robust fully managed feature set includes:

- IGMP Auto Configuration
- VLAN
- QoS
- Trunking
- Port Mirroring
- RSTP
- DHCP Server with Option 82 Relay Agent, Option 61, and IP Fallback
- *N-Ring* Technology
- *N-Link* Redundant *N-Ring* Coupling
- Port Security - MAC Address Based
- LLDP (Link Layer Discovery Protocol)
- Web Browser Management
- SNMP v1, v2, v3
- *N-View*™ OLE for Process Control Server Software
- Extended Environmental specifications: up to -40°C to 85°C
- Configurable Alarm Contact and Bi-Color Fault LED

EtherNet/IP with CIP Messaging is a standard feature on the 700 Series (excluding wireless), 7010TX, 7018TX, 7018FX2, and 7506GX2. CIP tags, sample projects, and diagnostic faceplates for FactoryTalk® View ME/SE software (requires RSLogix 5000 version 17 and higher) are provided for quick setup and configuration in RSLogix 5000 environments.

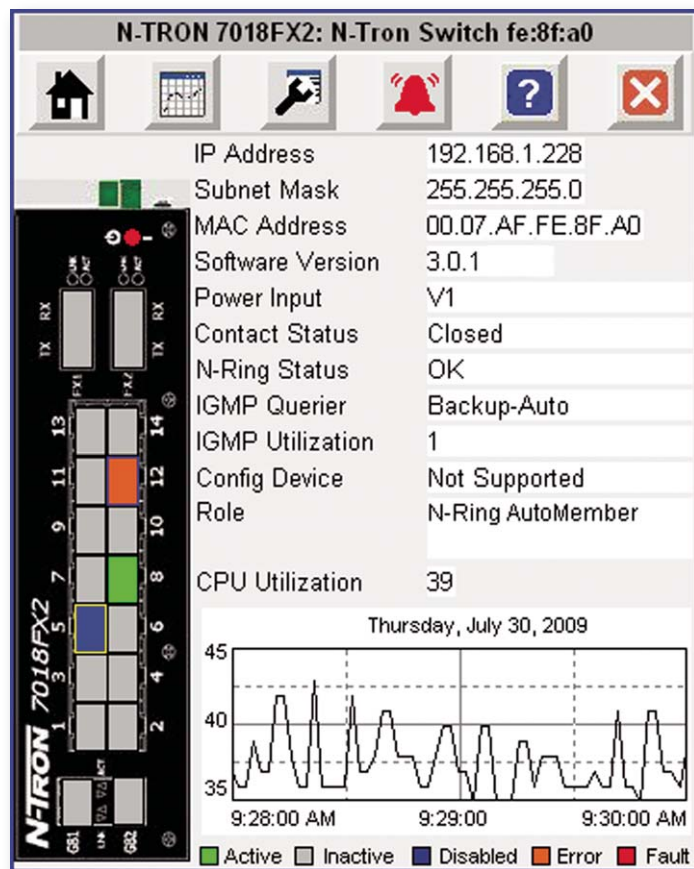

Quickly view switch status using our provide face plates or access tagged data from your ladder logic program.

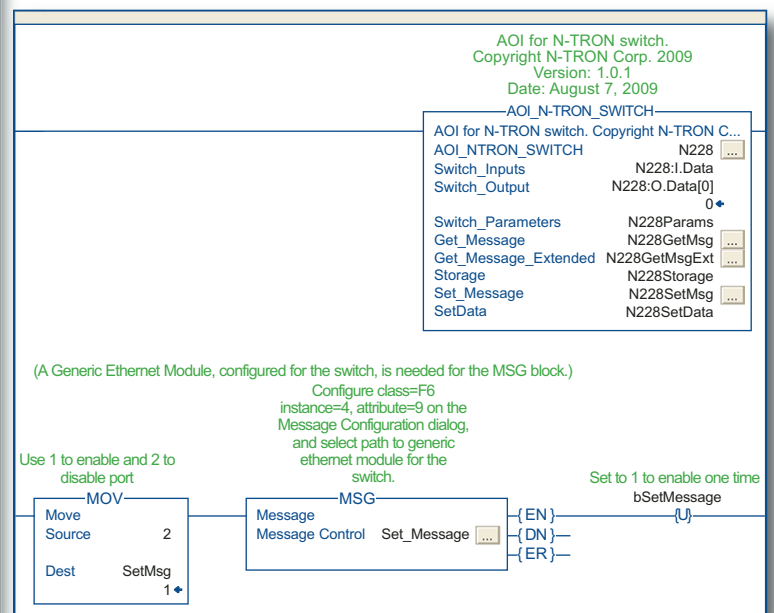

Fully Managed Gigabit Ethernet for High Traffic Industrial Applications



The *N-TRON* all-Gigabit 7506GX2 is designed to provide maximum performance in harsh, high traffic applications such as security and video surveillance.

The rugged 7506GX2 features four auto-sensing 10/100/1000BaseT(X) Mbps Ethernet ports and 2 SFP expansion ports for optional Multimode fiber, Singlemode fiber or 1000BaseT copper connections. The 7506GX2 comes standard with fully managed features such as: SNMP v3, jumbo frame support, web browser management, EtherNet/IP with CIP messaging, IGMP auto configuration, DSCP, LLDP, and DHCP Server with Option 82. An optional SD card may be purchased for saving or restoring the switch configuration.

Gigabit transceivers are available for purchase separately. Factory configured models are also available. (See ordering information below.)

7506GX2

- Four 10/100/1000BaseT(X) RJ-45 Copper Ports
- Two Optional Full Duplex 1000BaseSX/LX Gigabit SFP (Mini-GBIC) Transceivers or Two Optional 1000BaseT Gigabit SFP Transceivers
- Rugged Industrial DIN-Rail Enclosure
- Case Dimensions (3.8"h x 2.0"w x 3.9"d, 1.1 lbs.)
- -40°C to 80°C Operating Temperature
- ESD and Surge Protection Diodes on all Ports
Auto Sensing 10/100/1000BaseT(X), Duplex, and MDIX
- Onboard Temperature Sensor
- Configuration backup via Optional SD card
- Jumbo Frame Support
- Port Security - MAC Address Based
- SNMP v1, v2, v3, and Web Browser Management plus N-View OPC Monitoring with Fault Status for Ring Managers
- DHCP Server, Option 82 Relay, Option 61, IP Fallback, and Local IP Static Addressing
- Adv. Features: IGMP Auto Config., VLAN, DSCP, LLDP, QoS, Trunking, Mirroring, 802.1D RSTP, *N-Link* Redundant *N-Ring* Coupling, & EtherNet/IP CIP Messaging
- Ring Manager using *N-TRON*'s *N-Ring* Technology offers a Standard Healing Time of ~30ms
- Redundant Power Inputs 10-49 VDC, 440mA @ 24V

Ordering Information:

7506GX2

Four 10/100/1000BaseT(X) Ports and Two SFP ports without (optional) Modules

7506GX2-SX

Four 10/100/1000BaseT(X) Ports and Two SFP ports with 2 NTSPFP-SX Multimode modules installed

7506GX2-LX

Four 10/100/1000BaseT(X) Ports and Two SFP ports with 2 NTSPFP-LX-10 Singlemode modules installed

NTSFP-TX

Optional SFP Transceiver with One 1000BaseT GB Copper Port

NTSFP-SX

Optional SFP Transceiver with One 1000BaseSX Multimode GB Fiber Optic Port (LC Style Connector)

NTSFP-LX-ZZ

Optional SFP Transceiver with One 1000BaseLX-ZZ Singlemode GB Fiber Optic Port (LC Style Connector)

NTCD-128

Optional SD Card, Configuration Device

Ordering Key: MM = multimode fiber, SM = singlemode fiber, "E" = singlemode fiber, "ZZ" = 10, 40, or 80 for 10km, 40km, or 80km Gigabit Singlemode fiber length.

Fully Managed GbE Modular Switch, with RSTP and *N-Ring* Capability

The fully managed *N-TRON* 9000 Series Gigabit Ethernet capable industrial Ethernet switch offers superior performance and ease of use for Ethernet enabled industrial and security equipment.

With management features such as IGMP Snooping, VLAN, QoS, Port Mirroring, Port Trunking, and, 802.1w Rapid Spanning Tree Protocol (RSTP), the 9000 Series is designed to increase efficiency and network performance.

Advanced Management features can be configured using a Web Browser, SNMP, Telnet, or COM port.

The 9000 Series is an industrial four slot modular switch, offering two optional Gigabit ports, up to sixteen fiber optic ports, and up to twenty-four RJ-45 copper ports.

The Rapid Spanning Tree Protocol function allows the switch to be configured in a Ring or Mesh topology, and provides support for redundant path communications with rapid healing.

Used as a fiber optic Ring Manager, the 9000 Series switch, with *N-TRON's N-Ring* technology, offers expanded ring size capacity, detailed fault diagnostics, and a standard healing time of ~30ms.

The *N-TRON N-Ring* Manager sends out "Self Health" packets and "Ring Control" packets periodically around the fiber optic ring, for managing, detecting and restoring ring breaks. If these packets are successfully routed around the ring within the allocated time window, the ring is intact. However, if the ring is broken and the Ring Manager stops receiving these health check packets, it converts the ring to a fiber optic backbone configuration within ~30ms. When using all *N-TRON* fully managed switches in the ring, a detailed ring map and fault location chart will be provided on the Ring Manager's web browser to identify the health status of the ring.

***N-TRON's* 9000 Series switches meet the following regulatory approvals:**

- **UL 1604 C Listed (U.S. & Canada) Class I, Div. 2 Hazardous Location**
- **CE: EN61000-6-2,4, EN55011, EN61000-4-2,3,4,5,6**
- **ABS Type Approval (Maritime Applications)**
- **IEEE 1613 Compliance (Electric Utility Substation)**
- **FCC Part 15 Class A**
- **NEMA TS1/TS2 Compliance (Traffic Control)**



9000BP

- 9000BP High Speed Backplane with Four Slot DIN-Rail Modular Switch Chassis
- 9000CPU* Module
- 9002CPU* Module with Two 1000BaseSX/LX Gigabit SFP Transceivers See ordering information below for Multimode and Singlemode options
- Fully Managed Features: IGMP Auto Configuration, VLAN, QoS, Trunking, Port Mirroring and 802.1w Rapid Spanning Tree (RSTP)
- Full SNMP, Web Browsing, and N-View Switch Monitoring
- 9000 Series can be configured as *N-TRON's N-Ring* Manager to Create a Fiber Optic Ring with ~30ms Standard Healing
- Case Dimensions (5.2" h x 9.0" w x 5.6" d, 5 lbs. fully populated)
- -20°C to 70°C Operating Temperature
-40°C to 85°C Storage Temperature
- >1 Million Hours MTBF
- Redundant Power Inputs: 10-30 VDC, 1.1 A @ 24V with 9000BP & 9002CPU *N-TRON* NTPS-24-5 Power Supply recommended
- Order Backplane & Chassis Part #9000BP
*Either 9000CPU or 9002CPU is required to be installed in CPU slot of 9000BP
- Order CPU Part #9000CPU (for no Gigabit)
Order Gigabit CPU Part #9002CPU-SX (for MM), or #9002CPU-LX-ZZ (for SM)

Ordering Key: MM = multimode fiber, SM = singlemode fiber, Where "ZZ" = 10, 40, 80, for 10km, 40km, or 80km SM Gigabit fiber length.



9006TX

- Six Port 10/100BaseTX Copper Module
- Slide in module for 9000BP Backplane & Four Slot Chassis
- Auto Sensing Full/Half Duplex, Speed, and MDIX
- Full IEEE 802.3 and 1613 Compliance
- Full Wire Speed Communications
- Hardened ESD Port Protection
- Module Weight 0.5 lbs
- -20°C to 70°C Operating Temperature
- -40°C to 85°C Storage Temperature
- Redundant Power Inputs 10-30 VDC, 0.35A @ 24V
- >1 Million Hours MTBF
- Order Part #9006TX

9002FX

- Two Port 100BaseFX Module ST or SC Full Duplex
- Slide in module for 9000BP Backplane & Four Slot Chassis
- Multimode or Singlemode Fiber Available
- Full IEEE 802.3 and 1613 Compliance
- Full Wire Speed Communications
- Hardened ESD Port Protection
- Module Weight 0.5 lbs
- -20°C to 70°C Operating Temperature
- -40°C to 85°C Storage Temperature
- Redundant Power Inputs 10-30 VDC, 0.15A @ 24V
- >1 Million Hours MTBF
- Order MM Part #9002FX-XX
Order SM Part #9002FXE-XX-YY

9004FX

- Four Port 100BaseFX Module ST or SC Full Duplex
- Slide in module for 9000BP Backplane & Four Slot Chassis
- Multimode or Singlemode Fiber Available
- Full IEEE 802.3 and 1613 Compliance
- Full Wire Speed Communications
- Hardened ESD Port Protection
- Module Weight 0.6 lbs
- -20°C to 70°C Operating Temperature
- -40°C to 85°C Storage Temperature
- Redundant Power Inputs 10-30 VDC, 0.25A @ 24V
- >1 Million Hours MTBF
- Order MM Part #9004FX-XX
Order SM Part #9004FXE-XX-YY

Ordering Key: MM = multimode fiber, SM = singlemode fiber, "E" = singlemode fiber, "XX" = ST or SC for fiber style connector, "YY" = 15, 40, or 80 for 15km, 40km, or 80km SM fiber length.

N-TRON's New Line of Serial Communications Devices for Industrial Environments



The N-TRON family of serial devices includes a serial-to-fiber converter, an Isolator, a Repeater, and Serial-to-Ethernet converters. This wide array of serial products provide connectivity options for legacy serial equipment.

The Modbus gateway completes this family of products, providing the capability to translate Modbus/TCP to Modbus ASCII/RTU. These devices are DIN-Rail mountable, compact in size, have a high MTBF, and, like all N-TRON products, are designed to provide maximum network availability in rugged industrial environments.



ESERV-11T/12T

- Industrial Ethernet to Serial Server
- Up to Two Active Serial Ports
- One Ethernet Port Available w/ 10/100BaseTX or 100BaseFX-ST
- Connects RS-232, RS-422, or RS-485 Devices to LAN or WAN
- Wide Operating Temperature -34°C to 80°C
- 10 to 58VDC Input Power Range
- Supports Data Rates up to 230.4 Kbps
- Simple Configuration with Built-in Web Server
- Heartbeat Connection with Auto Detection and Reconnect
- DIN-Rail Case Dimensions (4.7" h x 1.2" w x 3.2" d, .33 lbs.)
- Order #ESERV-11T (1 Serial Port) or #ESERV-11-ST* (1 Serial Port)
- Order #ESERV-12T (2 Serial Ports) or #ESERV-12-ST* (2 Serial Ports)

ESERV-M12T

- Industrial Modbus Ethernet to Serial Gateway
- Two Active Serial Ports via TB Connectors
- One Ethernet Port Available w/ 10/100BaseTX or 100BaseFX-ST
- Connects Modbus Serial Devices to Modbus TCP, LAN or WAN
- Wide Operating Temperature -34°C to 80°C
- 10 to 58VDC Input Power Range
- Supports Data Rates up to 230.4 Kbps
- Simple Configuration with Built-in Web Server
- Heartbeat Connection with Auto Detection and Reconnect
- Modbus Messaging Priority Control - Real Time Messaging
- DIN-Rail Case Dimensions (4.7" h x 1.2" w x 3.2" d, .33 lbs.)
- Order Part #ESERV-M12T
Order Part #ESERV-M12-ST*

*Multimode Fiber with ST Style connectors.



SER-485-IC

- Industrial Isolated Converter
- RS-232 DB9 Female Serial Connector
- RS-422/485 Five Position Terminal Block
- Modbus, ASCII, RTU Compatible
- Wide Operating Temperature -40°C to 80°C
- 10 to 48VDC Input Power Range
- Supports Data Rates up to 115.2 Kbps
- 3-Way 2000V Optical Isolation
- Built-in Switchable Termination and Bias
- 12 Position DIP Switch Configuration
- DIN-Rail Case Dimensions (4.9" h x 1.3" w x 4.5" d, .45 lbs.)
- Order Part #SER-485-IC

SER-485-IR

- Industrial Isolated Repeater
- Two RS-232/485 Five Position Terminal Blocks
- Extends Signal up to 4,000 feet (1200 Meters)
- Modbus, ASCII, RTU Compatible
- Wide Operating Temperature -40°C to 80°C
- 10 to 48VDC Input Power Range
- Supports Data Rates up to 115.2 Kbps
- 3-Way 2000V Optical Isolation
- Built-in Switchable Termination and Bias
- 12 Position DIP Switch Configuration
- DIN-Rail Case Dimensions (4.9" h x 1.3" w x 4.5" d, .49 lbs.)
- Order Part #SER-485-IR

SER-485-FXC

- Industrial Serial to Multimode Fiber Converter
- RS-232/485 Five Position Terminal Block
- One 100BaseFX Multimode ST style Fiber Port
- Modbus, ASCII, RTU Compatible
- Wide Operating Temperature -40°C to 80°C
- 10 to 48VDC Input Power Range
- Supports Data Rates up to 115.2 Kbps
- 3-Way 2000V Optical Isolation
- Built-in Switchable Termination and Bias
- 12 Position DIP Switch Configuration
- DIN-Rail Case Dimensions (4.9" h x 1.3" w x 4.5" d, .44 lbs.)
- Order Part #SER-485-FXC

*Multimode Fiber with ST Style connectors.

N-Ring Health Diagnostics

N-Ring OK!!					
N-Ring Status View					
Switch is an N-Ring Manager					
Switch No	MAC Address	IP Address	Subnet Mask	Name	Ports
RM	00:07:af:ff:f6:e0	192.168.1.136	255.255.255.0	N-TRON Switch	A2
					A1
1	00:07:af:ff:f6:40	192.168.1.131	255.255.255.0	N-TRON Switch	A1
					A2
2	00:07:af:ff:f6:60	192.168.1.132	255.255.255.0	N-TRON Switch	A2
					A1
3	00:07:af:ff:f6:80	192.168.1.133	255.255.255.0	N-TRON Switch	A1
					A2
4	00:07:af:ff:f6:a0	192.168.1.134	255.255.255.0	N-TRON Switch	A2
					A1
5	00:07:af:ff:f6:c0	192.168.1.135	255.255.255.0	N-TRON Switch	A1
					A2

N-Ring™ is an exclusive feature of *N-TRON's* **700**, **7000** and **9000** Series Ethernet Switches offering detailed diagnostics, expanded ring size capacity, and ~30ms ring healing time. When using *N-TRON's* fully managed switches in a ring topology, a detailed ring map will appear on the Ring Manager's web browser to identify the health status of the ring. The order of switches and ports is dynamically generated when using *N-TRON's* fully managed switches to create the ring. The chart to the left shows a healthy ring status view indicating that all of the switches in the ring are communicating and no breaks have been detected.

The map to the right shows a *N-Ring* fault status view indicating that a fault has been detected in the *N-TRON* fully managed network. This fault map shows a communication error has occurred between the A2 port of Switch 1 and the A2 port of Switch 2. In this case the Ring manager declared a fault and converted the ring to a fiber optic backbone within ~30ms, allowing communication of the ring to continue until the declared switches and cable segments can be evaluated and repaired in the field.

N-Ring Fault!					
N-Ring Status View					
Switch is an N-Ring Manager					
Switch No	MAC Address	IP Address	Subnet Mask	Name	Ports
RM	00:07:af:ff:f6:e0	192.168.1.136	255.255.255.0	N-TRON Switch	A2
					A1
1	00:07:af:ff:f6:40	192.168.1.131	255.255.255.0	N-TRON Switch	A1
					A2
2	00:07:af:ff:f6:60	192.168.1.132	255.255.255.0	N-TRON Switch	A2
					A1
3	00:07:af:ff:f6:80	192.168.1.133	255.255.255.0	N-TRON Switch	A1
					A2
4	00:07:af:ff:f6:a0	192.168.1.134	255.255.255.0	N-TRON Switch	A2
					A1
5	00:07:af:ff:f6:c0	192.168.1.135	255.255.255.0	N-TRON Switch	A1
					A2

Star

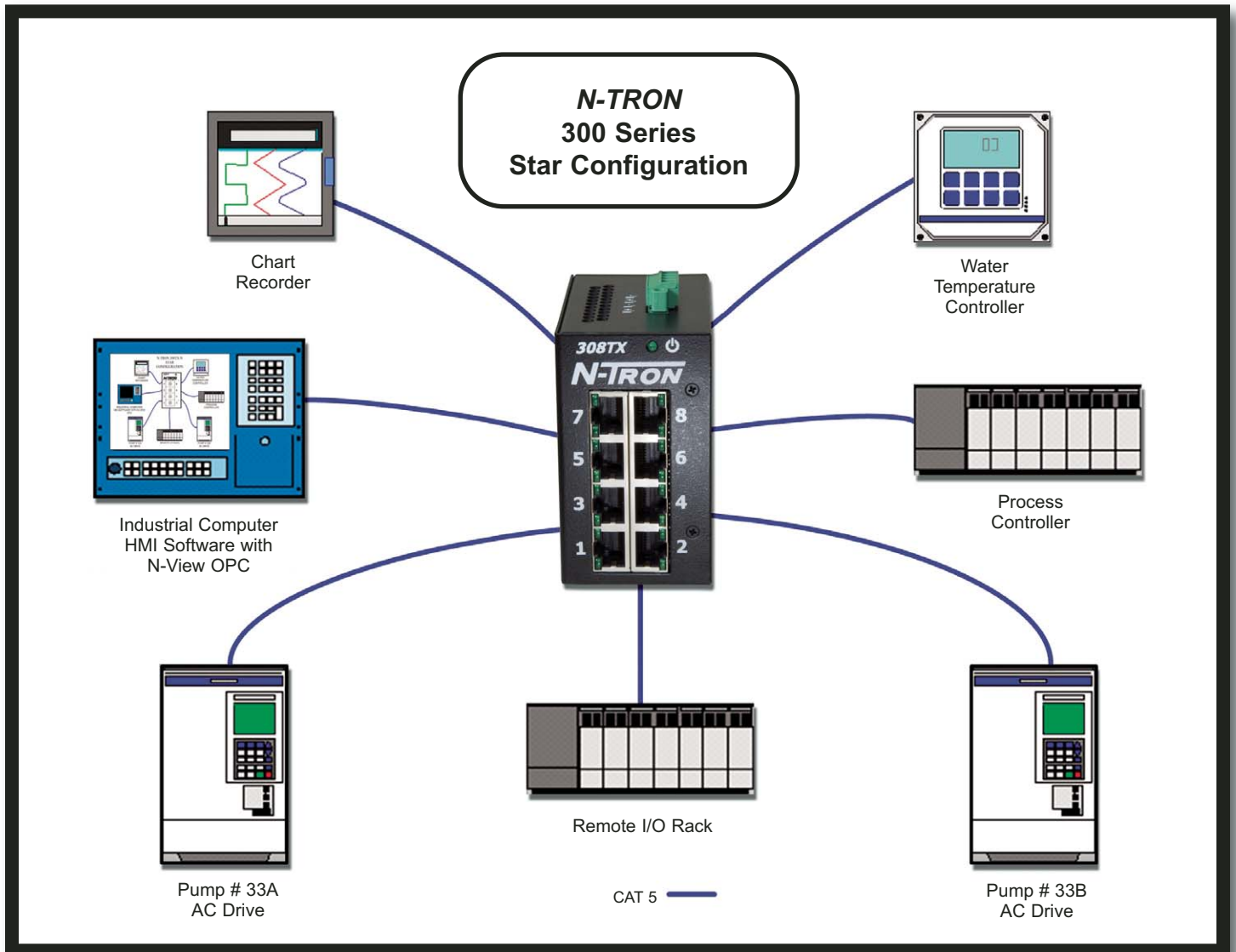

The star is the most efficient network topology for data acquisition and control systems. Because the MTBF of an *N-TRON* industrial switch is in excess of 2M hours, the likelihood of a switch or media failure is remote. *N-TRON* switches offer dual power supply inputs to eliminate the possibility of a single power supply failure bringing the network down. The star topology also allows for the utilization of lower cost layer 2 switches and provides an order of magnitude speed improvement over ring topology. The star topology can easily be implemented with fiber and/or copper. This network is simple to maintain and troubleshoot. The N-View option will add remote monitoring capability to your control system network. The N-View OPC Server, when combined with any standard OPC client HMI software package, will provide full network monitoring and alarming capability. N-View is available on the 200, 300, 400, 500, 700, 900, 7000, and 9000 Series switches.

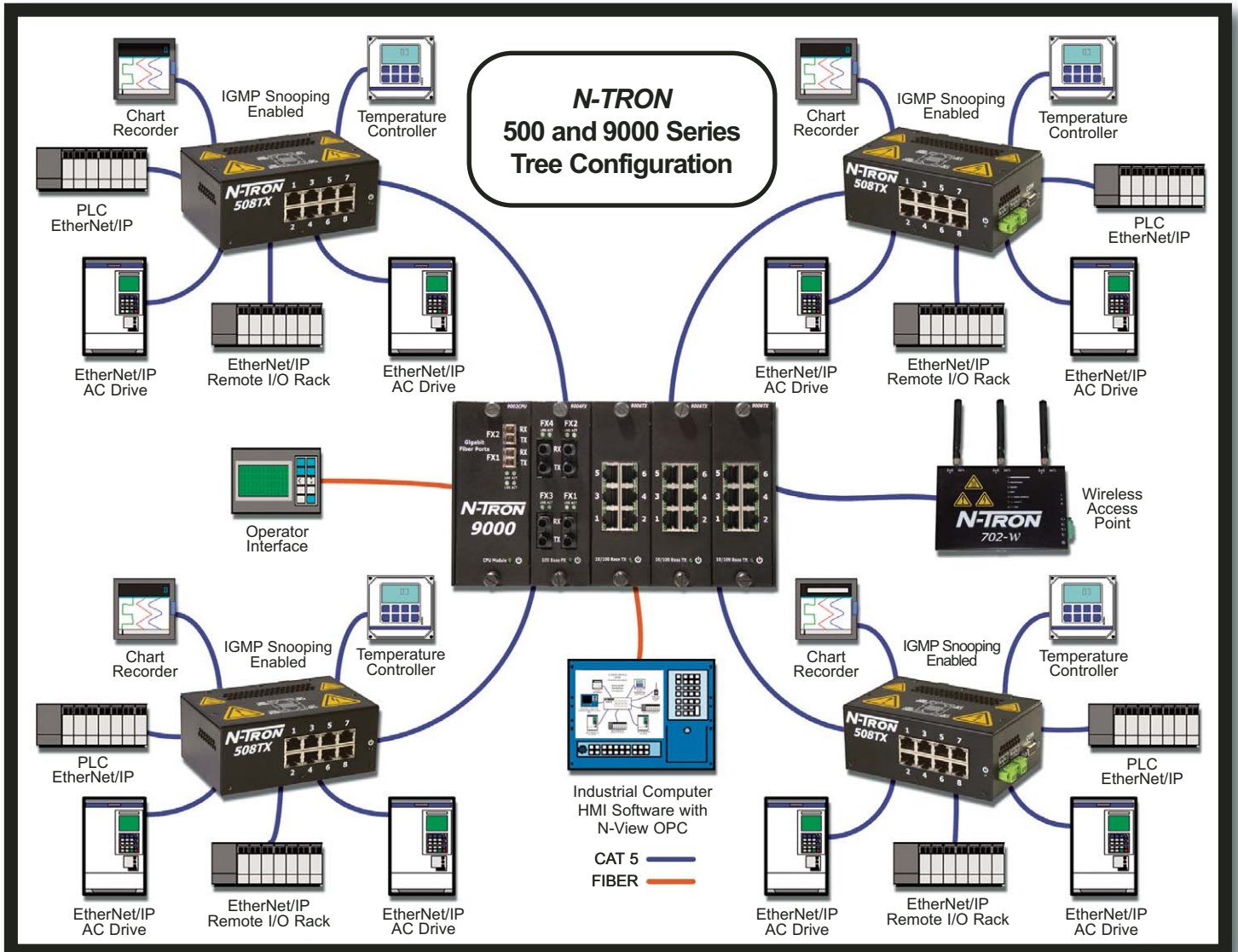

The tree topology uses a combination of several switches to form a single network. This topology provides the most efficient method of interconnecting multiple control systems. The above diagram highlights the Internet Group Management Protocol (IGMP). IGMP is frequently used by control systems to route multicast packets for communication between control devices. The routing of the IGMP multicast packets is essential to prevent multicast traffic from adversely affecting upstream network devices such as routers, wireless access points, RS232/485 to Ethernet converters, or any other network device which can not transmit or process packets at full wire speed. This feature allows IGMP capable switches to forward multicast packets based on learned group addresses. Each switch will transmit copies of a specific multicast message only to ports that have joined that multicast group. These addresses are learned by detecting group join packets sent by devices connected to the switch without the need of an expensive router.

Wireless and PoE Bridge

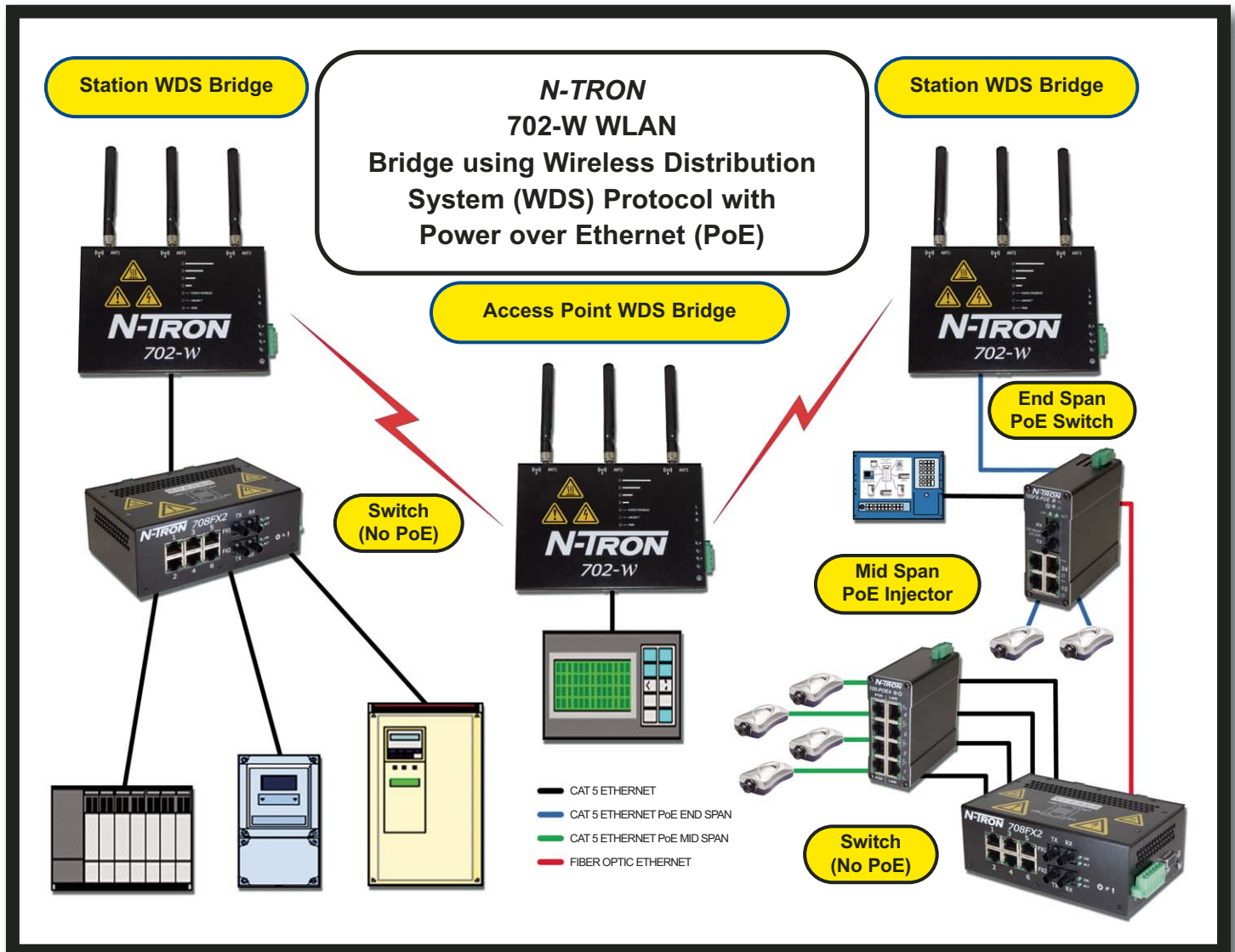

N-TRON's new 702-W high performance hardened wireless technology can be configured to provide a high speed wireless infrastructure for process control, security, and many other applications requiring IEEE 802.11a, b, g, or n connectivity. The need to gather data from and provide data to equipment and employees moving around a facility is one of the primary applications for these devices. Wireless communication may be used to link remote locations that require monitoring or data services without the need to install costly Category 5/6 cable or Fiber optic cable. The 702 Series is available in both indoor and outdoor models. The 702M12-W utilizes an IP67 water tight enclosure. Both models can be powered using PoE or redundant (20VDC to 49VDC) power supplies. N-TRON antennas, cable assemblies, and mounting options can be found on our accessories page.

Media Redundant Fiber Ring

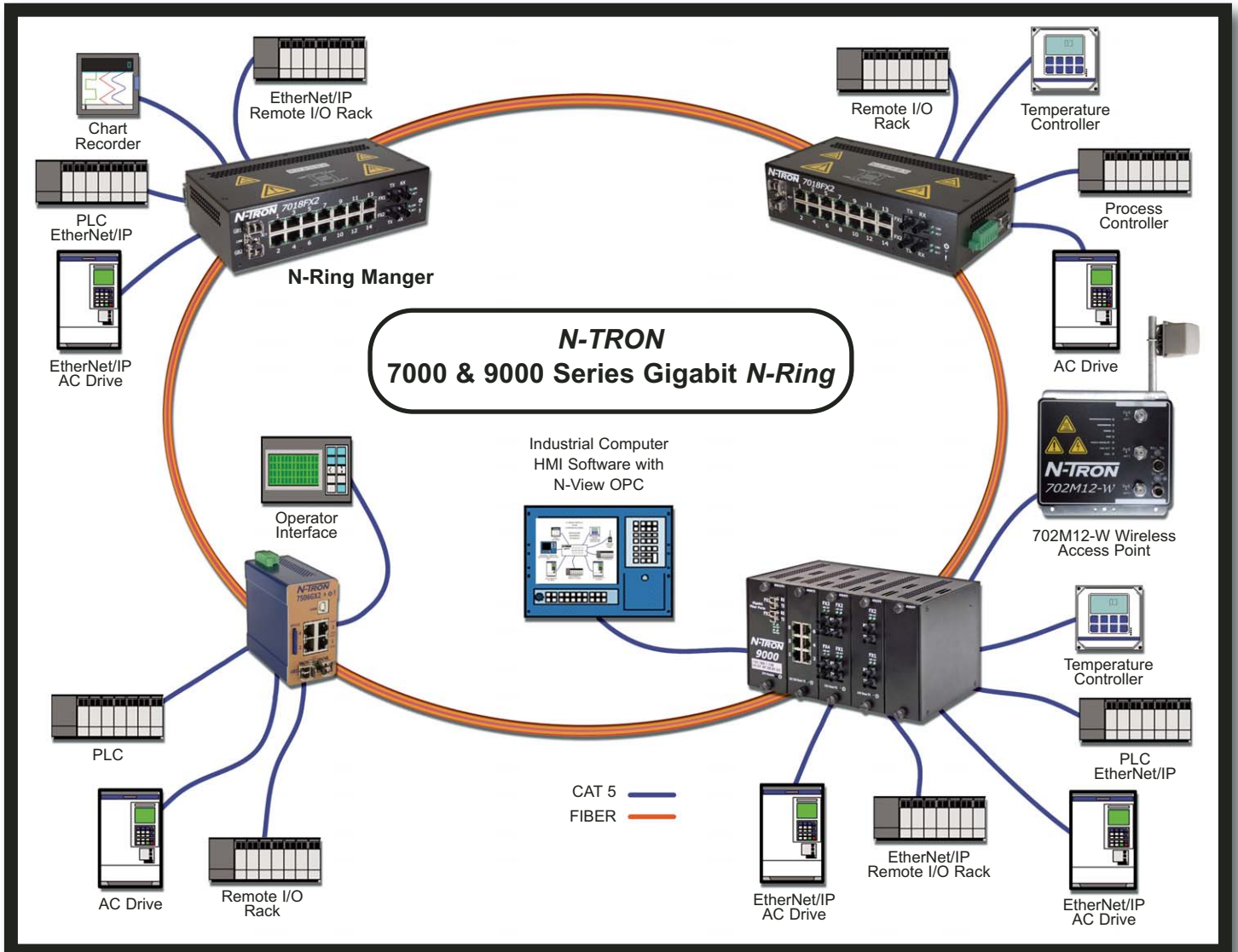

The performance of a media redundant fiber ring network can be greatly enhanced by using products with *N-TRON's N-Ring™* technology. The topology above features a 7000 Series Ring Manager in a Gigabit *N-Ring*. The *N-Ring* Manager sends out "Self Health" and "Ring Control" packets periodically around the fiber ring. If these packets are successfully routed around the ring within the allocated time frame, the ring is declared to be intact. However, if the ring is broken and the Ring Manager stops receiving these health check packets, it converts the ring to a fiber optic backbone within ~30ms. When using *N-TRON* fully managed switches in the ring, a detailed ring map and fault location chart will be provided on the Ring Manager's web browser to identify the health status of the ring. *N-TRON's* 700 Series switches can be used in this same topology as the fiber optic Ring Manager.

N-Ring with N-Link

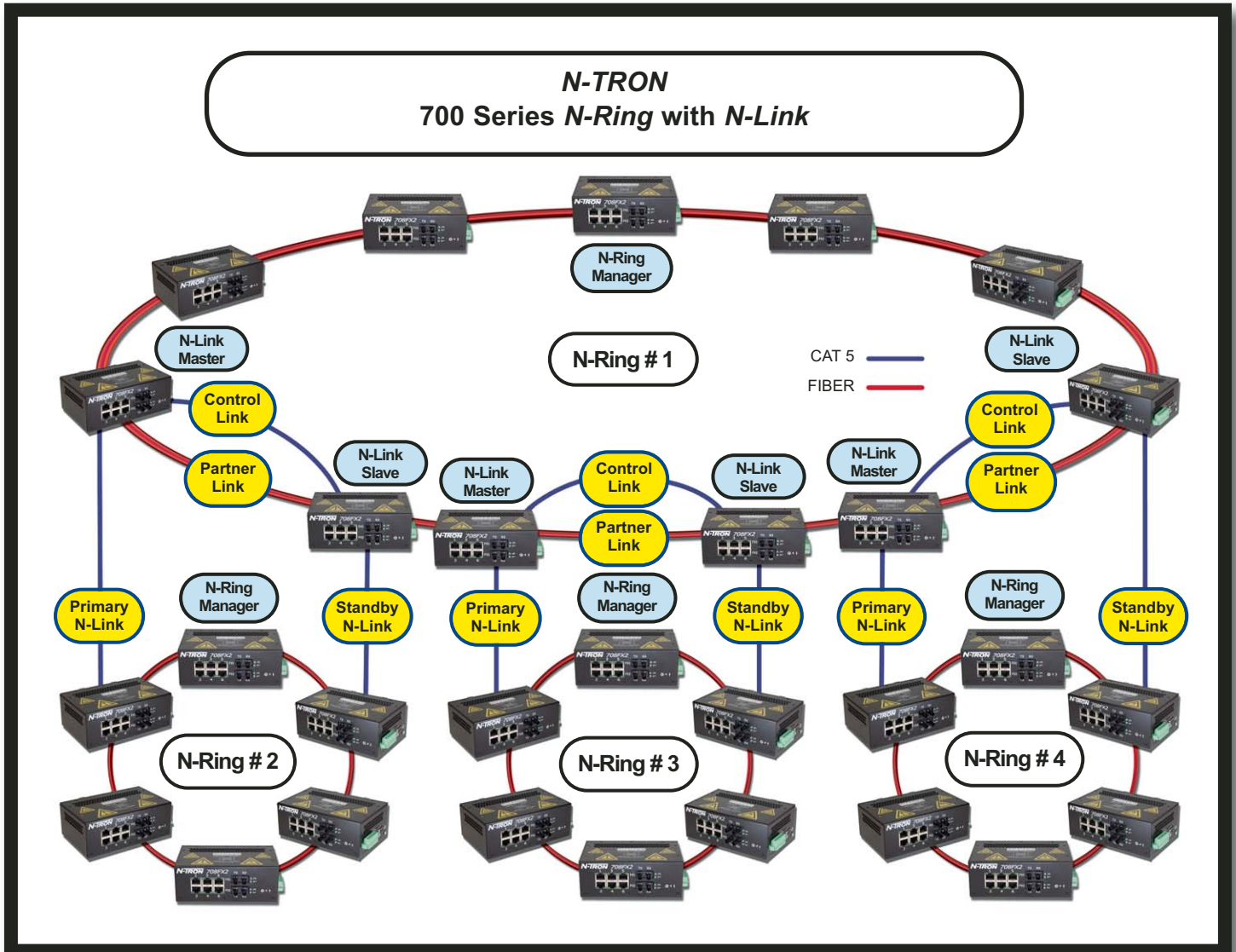

N-Link will allow the connection of two or more N-Rings to provide added hardware redundancy or to run interconnected N-Rings for a distributed N-Ring Topology. The N-Link connections form redundant media links between two N-Rings and will monitor them to determine if the links are intact. If a break in the primary link occurs, traffic will be rerouted through the standby link within 30ms. A single N-Ring can support up to 126 N-Linked N-Rings. This topology is ideal for subway, light rail, pipeline substation, utility substation and other application requiring distributed high speed ring topology. N-Link is available on N-TRON's 700, 7010, 7018, and 7506 Series.

N-TRON Peripherals and Accessories

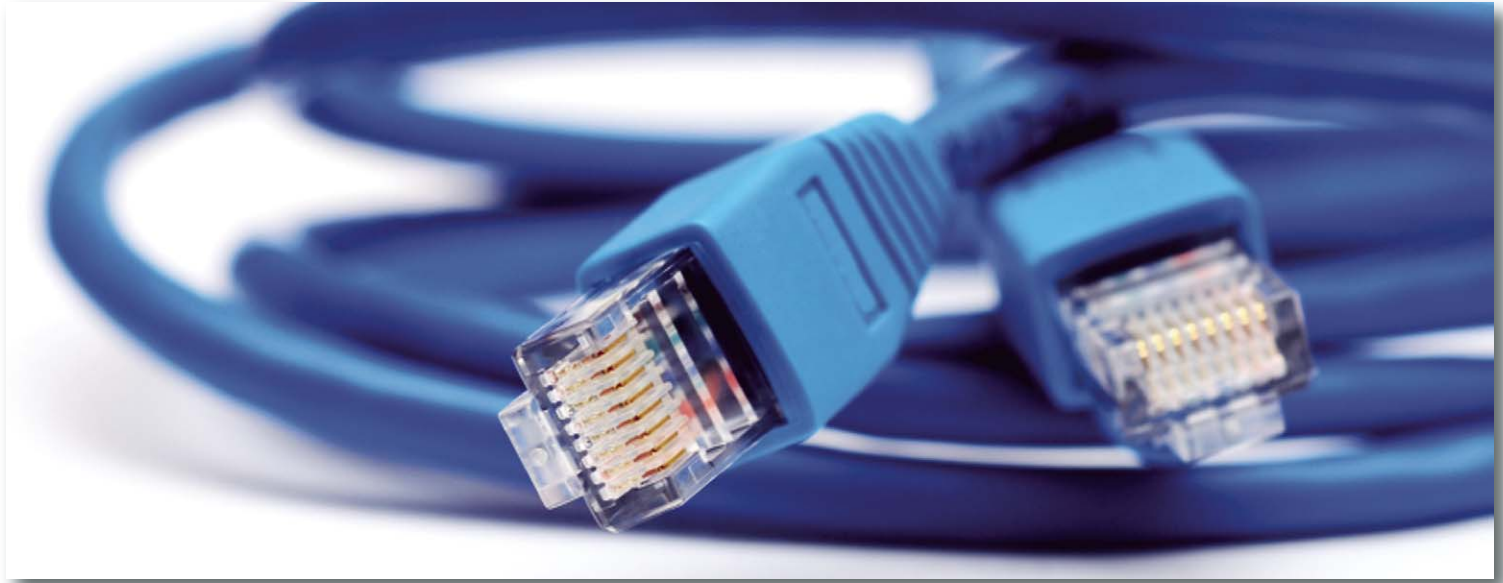

Cables

	2ZR6AA-X	Multimode Duplex Fiber Optic Cable, 62.5/125um, 1310nm, ST-ST Connectors
	2ZR6AB-X	Multimode Duplex Fiber Optic Cable, 62.5/125um, 1310nm, ST-SC Connectors
	2ZR6AC-X	Multimode Duplex Fiber Optic Cable, 62.5/125um, 850nm, ST-LC Connectors
	2ZR6BB-X	Multimode Duplex Fiber Optic Cable, 62.5/125um, 1310nm, SC-SC Connectors
	2ZR6BC-X	Multimode Duplex Fiber Optic Cable, 62.5/125um, 850nm, SC-LC Connectors
	2ZR6CC-X	Multimode Duplex Fiber Optic Cable, 62.5/125um, 850nm, LC-LC Connectors
	2ZR8AA-X	Singlemode Duplex Fiber Optic Cable, 8.3/125um, 1310nm, ST-ST Connectors
	2ZR8AB-X	Singlemode Duplex Fiber Optic Cable, 8.3/125um, 1310nm, ST-SC Connectors
	2ZR8AC-X	Singlemode Duplex Fiber Optic Cable, 8.3/125um, 1310nm, ST-LC Connectors
	2ZR8BB-X	Singlemode Duplex Fiber Optic Cable, 8.3/125um, 1310nm, SC-SC Connectors
	2ZR8BC-X	Singlemode Duplex Fiber Optic Cable, 8.3/125um, 1310nm, SC-LC Connectors
	2ZR6CC-X	Singlemode Duplex Fiber Optic Cable, 8.3/125um, 1310nm, LC-LC Connectors
	06AR6-X	Multimode, 6 Strand Fiber Optic Cable, 62.5/125um, 1310nm, Armored ST-ST Connectors

Cables Ordering Key: "X" = Length in feet

	ANT-CAB-195-RPSMA-RPSMA-X	702-W Antenna Bulkhead Extension Cable Set; Each Cable includes (1) Straight RP-SMA Bulkhead Jack and (1) 90° RP-SMA Plug (package of 3)
	ANT-CAB-400-N-RPSMA-X	Low Loss CA-400 Coaxial Cable with 1 RP-SMA Connector & 1 N Male Connector for N-TRON's 702-W
	ANT-CAB-400-N-RPTNC-X	Low Loss CA-400 Coaxial Cable with 1 RP-TNC Connector & 1 N Male Connector for N-TRON's 702M12-W
	CAT5E-X	Cat5e Shielded Twisted Pair Cable, RJ-45 Connectors with Strain Relief Boots, Shielded
	CAT5E-M12-M12-X	Cat5e Shielded Twisted Pair with Straight M12 to Straight M12 Connectors, Shielded
	CAT5E-M12-RJ45-X	Cat5e Shielded Twisted Pair with Straight M12 to RJ-45 Connectors, Shielded
	CAT5E-M12-X	Cat5e Shielded Twisted Pair with Straight M12 Connector to Bare End, Shielded
	CAT5E-RM12-M12-X	Cat5e Shielded Twisted Pair with 90° M12 to Straight M12 Connectors, Shielded
	CAT5E-RM12-RM12-X	Cat5e Shielded Twisted Pair with 90° M12 to 90° M12 Connectors, Shielded
	CAT5E-RM12-RJ45-X	Cat5e Shielded Twisted Pair with 90° M12 to RJ-45 Connectors, Shielded
	CAT5E-RM12-X	Cat5e Shielded Twisted Pair with 90° M12 Connector to Bare End, Shielded
	PWR-M12-A-X	Power Cable, Straight M12 A-coded Female Connector to Bare End, Shielded
	PWR-RM12-A-X	Power Cable, 90° M12 A-coded Female Connector to Bare End, Shielded
	SERIAL-DB9-M12	Serial Cable with DB-9 to Straight M12 Connectors, 5ft in length, Shielded
	SERIAL-DB9-RM12	Serial Cable with DB-9 to 90° M12 Connectors, 5ft in length, Shielded

Power Supplies



- NTPS-24-1.3** DIN-Rail Power Supply for *N-TRON's* 100, 200, 300, 400, 500*, 600, 700, 900*, 1000, & 7000 Series Products. 1.3 Amp @ 24 VDC (*When operating two or more 900 Series fiber modules, 524TX, or 526FX2, use NTPS-24-3)
- NTPS-24-3** DIN-Rail Power Supply for *N-TRON's* Products, especially suited for 524TX, 526FX2, & 900 Series. 3.0 Amp @ 24 VDC
- NTPS-24-5** DIN-Rail Power Supply for *N-TRON's* Products, especially suited for 9000 Series. 5.0 Amp @ 24 VDC
- NTPS-24-TT-XXX** Table Top Power Supply for *N-TRON's* 100, 200, 300, 400, 500, & 700 Series Products. Amperage varies per Series, Pre-Terminated, ~12ft. Not for use with M12, PoE, HV, 524TX, or 526FX2 models.
- NTPS-24-WA-XXX** Wall Adaptor Power Supply for *N-TRON's* 100, 200, 300, 400, 500, & 700 Series Products. Amperage varies per Series, Pre-Terminated, ~6ft. Not for use with M12, PoE, HV, 524TX, or 526FX2 models.
- NTPS-48-2** DIN-Rail Power Supply for *N-TRON's* 100 Series PoE or High Voltage Products. 2.0 Amp @ 48 VDC
- NTPS-48-5** DIN-Rail Power Supply for *N-TRON's* 100 Series PoE or High Voltage Products. 5.0 Amp @ 48 VDC
- NTSA-CAT5e** In-Line, DIN-Rail Cat5e Surge Arrester effective

Power Supplies Ordering Key: "XXX" = *N-TRON* series # receiving power

Configuration and Recovery Devices



- NTCD-128** SD Card, Configuration Recovery Device
- 700-NTCD-M12** Configuration Recovery Device for use with *N-TRON's* 708M12 Series Switches, Straight M12 A-Coded 4-Pin Male Connector

Mounting Kits



- 300-PM** Panel Mount Kit for *N-TRON's* 100*, & 300 Series Products. Converts Switch from DIN-Rail to Panel Mount. (*102MC-FL & 102PC-SE only)
- 500-UTA89** Metal DIN-Rail Clip for *N-TRON's* 508TX, 508FX2, & 509FX Switches.
- 700-PM** Panel Mount Kit for *N-TRON's* 700 & 7000 Series Switches excluding 702-W, 702-M12-W, & 708M12.
- 702-W-PM** Panel Mount Kit for *N-TRON's* 702-W Radio
- 702M12-PK** Pole Mount Kit for *N-TRON's* 702M12-W Radio
- 900-PM** Panel Mount Kit for *N-TRON's* 200, 300, 400, 500*, 700, & 900 Series. Converts Switch from DIN-Rail to Panel Mount. (*Excluding 524TX, & 526FX2)
- 1000-PM** Panel Mount Kit for *N-TRON's* 1000 & 7506 Series
- 7000-UTA89** Metal DIN-Rail Clip for *N-TRON's* 7000 Series to allow for Horizontal Mounting in Smaller Spaces.
- 9000-PM** Panel Mount Kit for *N-TRON's* 9000BP Chassis. Converts Switch from DIN-Rail to Panel Mount.
- 9000-UTA107** Metal DIN-Rail Clip for *N-TRON's* 9000BP Chassis. 1 clip include. 2 additional clips may be installed.
- CPMA-1** Metal Panel Mount Option for the 709FX, 710FX2, 711FX3, and 7010TX products. Factory installed option must be specified with switch order.
- CPMA-2** Metal Panel Mount Option for the 712FX4 and 714FX6 products. Factory installed option must be specified with switch order.
- M12DRC-ISO** DIN-Rail Kit for *N-TRON's* M12 Products. Two Isolated Plastic DIN-Rail Clips and Mounting Clips Included.
- M12DRC-MTL** DIN-Rail Kit for *N-TRON's* M12 Products. Two Metal DIN-Rail Clips and Mounting Clips Included.
- URMK (or 900-RM)** 19" Rackmount Kit for *N-TRON's* 100, 200, 300, 400, 500*, 700, 900, 7000, & 9000 Series. Allows DIN-Rail Switches to be Rackmounted. (*19" Rackmount brackets standard on 524TX & 526FX2)

Antennas and Wireless Accessories



- ANT-MD24-12** 2.4 GHz, 12dBi Mini Directional Antenna
- ANT-PAD-24-16** 2.4 GHz, 16dBi Panel Directional Antenna
- ANT-PAD-58-19** 5.8 GHz, 19dBi Panel Directional Antenna
- ANT-PD58-32** 5.8 GHz, 32dBi Parabolic Dish Antenna
- ANT-DB1-RAF-RPSMA** 702-W Dual Band Antenna, RP-SMA (Replacement Part; Qty. = 1)
- ANT2458Q5P2** 702M12-W Dual Band Antenna, IP-67 O-Ring, RP-TNC (Replacement Part; Qty. = 1)

SFP (Mini GBIC) Transceivers



- NTSFP-TX** 1000BaseT Copper SFP Pluggable Mini-GBIC Transceiver (RJ-45 Connectors)
- NTSFP-SX** 1000BaseSX Multimode Fiber SFP Pluggable Mini-GBIC Transceiver (LC Style Connector, 550m)
- NTSFP-LX-10** 1000BaseLX Singlemode Fiber SFP Pluggable Mini-GBIC Transceiver (LC Style Connector, 10km)
- NTSFP-LX-40** 1000BaseLX Singlemode Fiber SFP Pluggable Mini-GBIC Transceiver (LC Style Connector, 40km)
- NTSFP-LX-80** 1000BaseLX Singlemode Fiber SFP Pluggable Mini-GBIC Transceiver (LC Style Connector, 80km)

N-TRON



YOUR INDUSTRIAL ETHERNET SOLUTION



N-TRON Headquarters

820 S. University Blvd., Ste. 4E
Mobile, AL 36609 USA
Phone: +1-251-342-2164
Fax: +1-251-342-6353

N-TRON Asia

Shanghai, P.R. China

Phone: +86-021-6194-6777
Fax: +86-021-6194-6699

Bangalore, India

Phone: +91-9844-876540

Singapore

Phone: +65-8118-6821

N-TRON Europe GmbH

Cham / ZG Switzerland

Phone: +41-41-740-6636
Fax: +41-41-740-6637

Runcorn, Cheshire, UK

Phone: +44 (0) 1928-577257
Cell: +44 (0) 7951-888621

www.n-tron.com • N-TRON_Sales@n-tron.com